

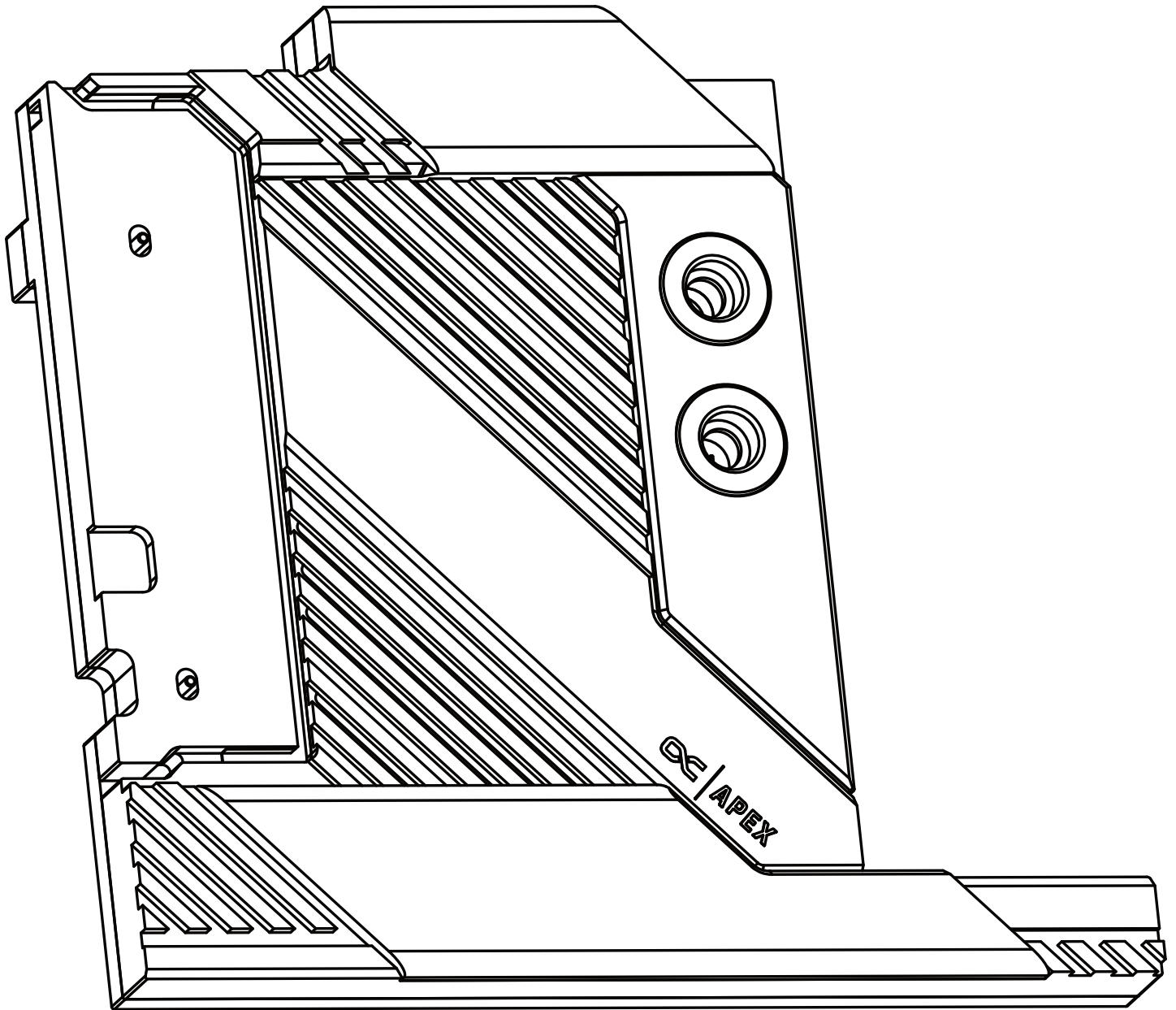

alphacool



Alphacool
Apex Monoblock
ROG STRIX X870E-E Gaming WIFI

EN	DE	FR	
Table of Contents	Inhaltsverzeichnis	Table des matières	
Accessories	Zubehör	Accessoires	3
Disassembly of the mainboard: M.2 SSD cooler	Demontage des Mainboards: M.2 SSD-Kühler	Démontage de la carte mère : Refroidisseur SSD M.2	4
Disassembly of the mainboard: M.2 SSD cooler	Demontage des Mainboards: M.2 SSD-Kühler	Démontage de la carte mère : Refroidisseur SSD M.2	5
Disassembly of the mainboard: IO-cover and VRM cooler	Demontage des Mainboards: IO-Abdeckung und VRM-Kühler	Démontage de la carte mère : Couvercle IO et refroidisseur VRM	6
Disassembly of the mainboard: IO-cover and VRM cooler	Demontage des Mainboards: IO-Abdeckung und VRM-Kühler	Démontage de la carte mère : Couvercle IO et refroidisseur VRM	7
Disassembly of the mainboard: Disconnect the display cable from the mainboard	Demontage des Mainboards: Displaykabel vom Mainboard trennen	Démontage de la carte mère : Déconnecter le câble de l'écran de la carte mère	8
Disassembly of the mainboard: Remove the cooler from the IO cover	Demontage des Mainboards: Kühler vom IO-Cover demontieren	Démontage de la carte mère : Retirer le refroidisseur du couvercle IO	9
Disassembly of the mainboard: Remove the cooler and M.2 SSD holder	Demontage des Mainboards: Kühler und M2-SSD-Halterung demontieren	Démontage de la carte mère : Retirer le refroidisseur et le support SSD M.2	10
Disassembly of the mainboard: Remove the cooler and M.2 SSD holder	Demontage des Mainboards: Kühler und M2-SSD-Halterung demontieren	Démontage de la carte mère : Retirer le refroidisseur et le support SSD M.2	11
Disassembly of the mainboard: Final step	Demontage des Mainboards: Letzter Schritt	Démontage de la carte mère : Dernière étape	12
Remove two-piece retention frame	Zweiteilige Kühlerhalterung demontieren	Retirer les deux supports pour dissipateur AMD	13
Install M.2 SSDs	M.2 SSDs installieren	Installation de disques SSD M.2	13
Screwing the IO cover to the monoblock	IO-Cover mit Monoblock verschrauben	Vissage du couvercle IO sur le monobloc	14
Place thermal pads on cooling block	Wärmeleitpads auf dem Kühlblock platzieren	Placer les pads thermique sur le bloc	14
Remove the protective film	Schutzfolie entfernen	Retirer le film de protection	15
Connecting the display cable to the mainboard	Displaykabel mit Mainboard verbinden	Connexion du câble d'affichage à la carte mère	15
Preparation: Clean the CPU and apply Thermal Grease	Vorbereitung: CPU reinigen und Wärmeleitpaste auftragen	Préparation: Nettoyer l'UCT et appliquer la pâte thermique	16
Install Monoblock cooler	Monoblock-Kühler montieren	Installer un refroidisseur monobloc	17
Secure monoblock with 4 screws	Monoblock mit 4 Schrauben sichern	Fixer le monobloc avec 4 vis	18
Connect ARGB lighting	ARGB Beleuchtung anschließen	Connecter l'éclairage ARGB	19
Notes	Notizen	Notes	19



Safety instructions
Sicherheitshinweise
Avis de sécurité



Digital guide
Digitale Anleitung
Guide digital



EN

Accessories

DE

Zubehör

FR

Accessoires

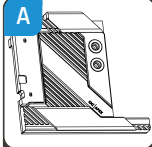

1x
Apex
Monoblock

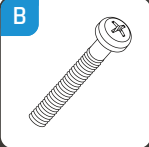

2x
M2x20mm
Screw

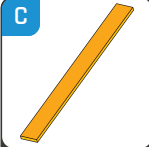

4x
85x8x2mm
Pad

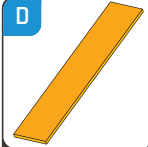

1x
75x22x2mm
Pad

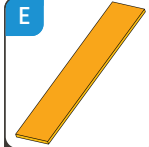

2x
70x22x2mm
Pad

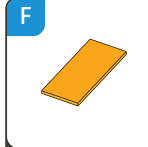

1x
11x15x2mm
Pad

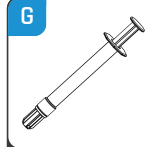

1x
Thermal
Grease

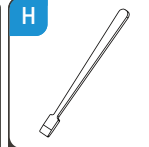

1x
Putty tool

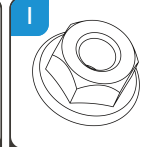

4x
AM5 Mounting
Nut

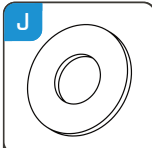

4x
Washer

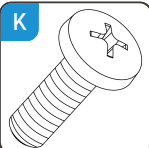

4x
M3x8mm
Screw

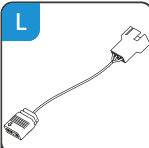

1x
ARGB
Adapter

Loosen the 4 screws of component M1 and remove the cooler. Loosen component M2 using the "Push" button.

4 Schrauben des Bauteils M1 lösen und Kühler abnehmen. Bauteil M2 mit der "Push"-Taste lösen.

Desserrer les 4 vis du composant M1 et retirer le refroidisseur. Desserrer le composant M2 à l'aide du bouton « Push ».



The M2 memory slots should be visible.

Die M2-Speichersteckplätze sollten sichtbar sein.

Les emplacements de mémoire M2 doivent être visibles.



Disassemble component M3.

Bauteil M3 demontieren.

Démonter le composant M3.



Turn the mainboard over and loosen 5 screws to remove component M3.

Mainboard umdrehen und 5 Schrauben lösen, um Bauteil M3 ab zu nehmen.

Retournez la carte mère et desserrez les 5 vis pour retirer le composant M3.

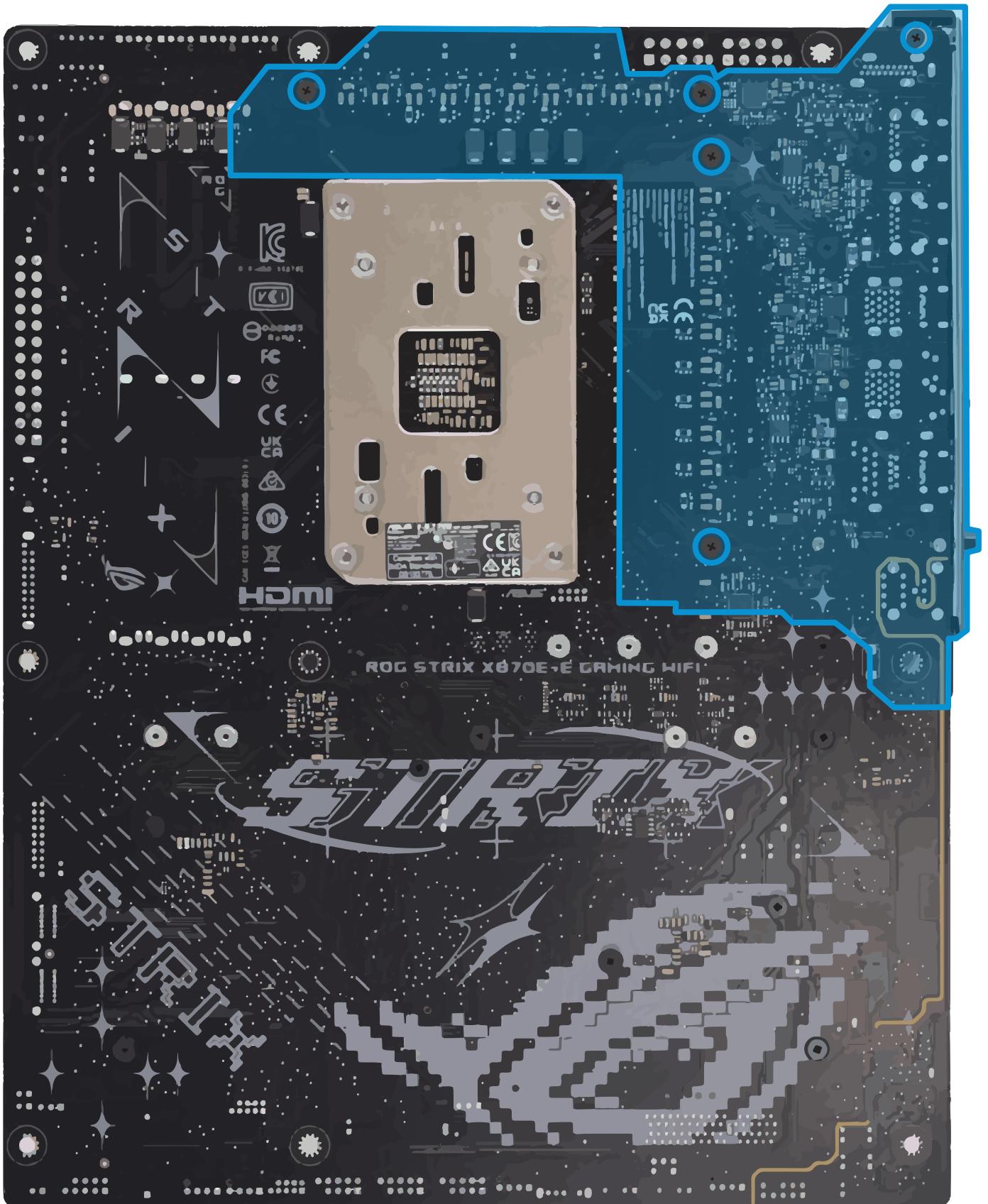

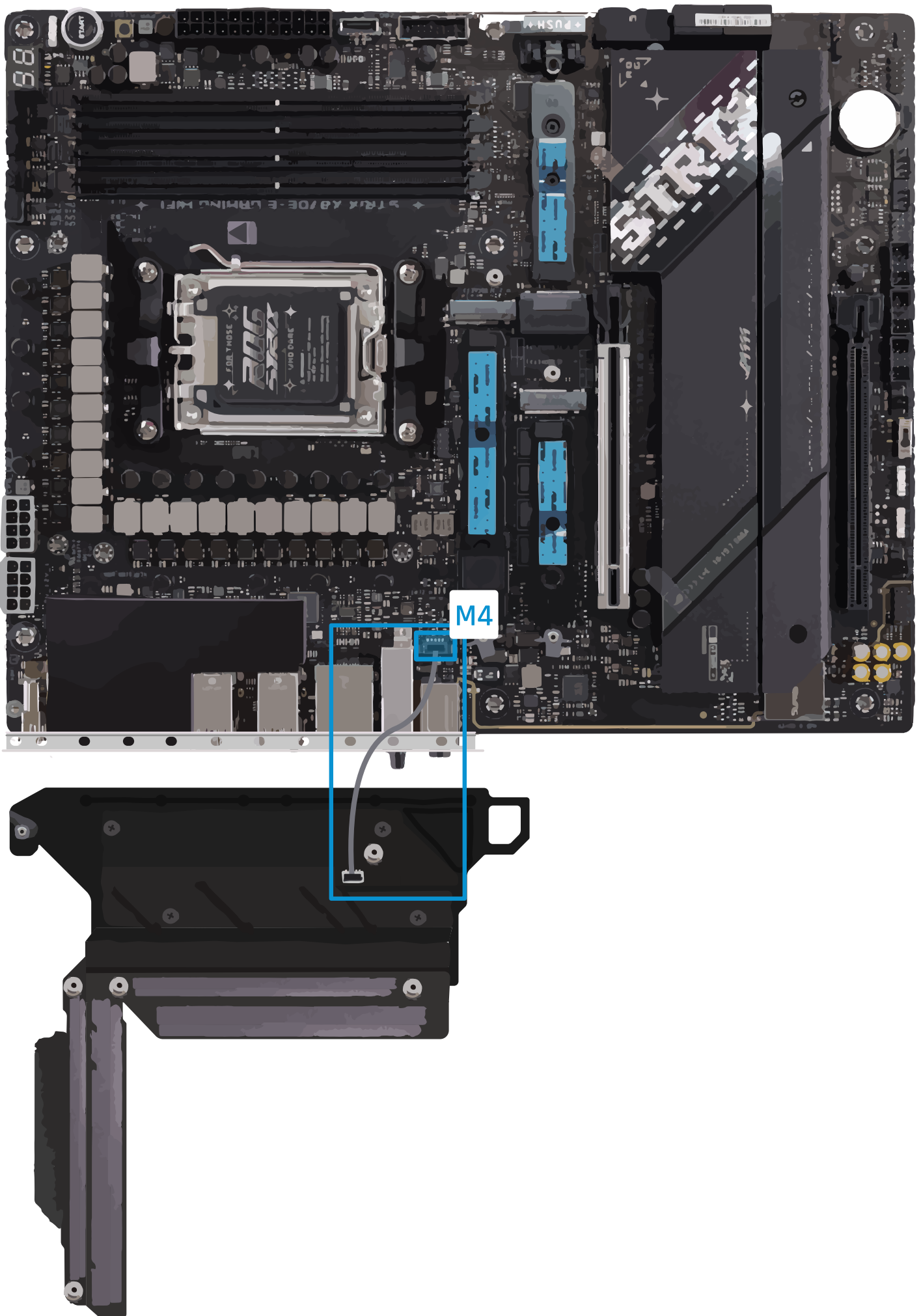

Loosen 4 screws to separate the IO cover with display from the cooler.

4 Schrauben lösen, um IO-Cover mit Display vom Kühler zu trennen.

Desserrez les 4 vis pour séparer le couvercle IO avec l'écran du refroidisseur.

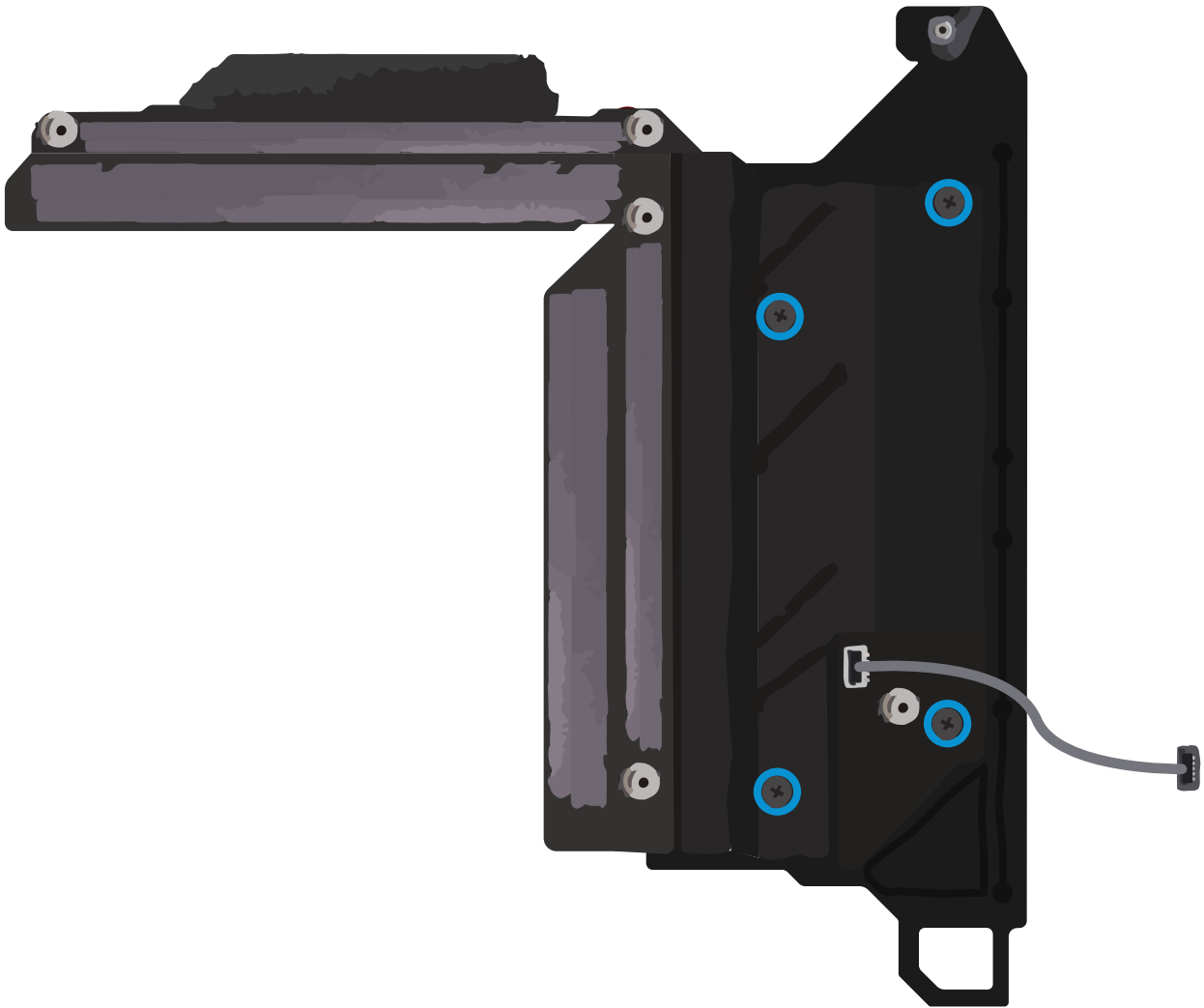

Remove component M5 and M6.

Bauteil M5 und M6 demontieren.

Retirer les composants M5 et M6.

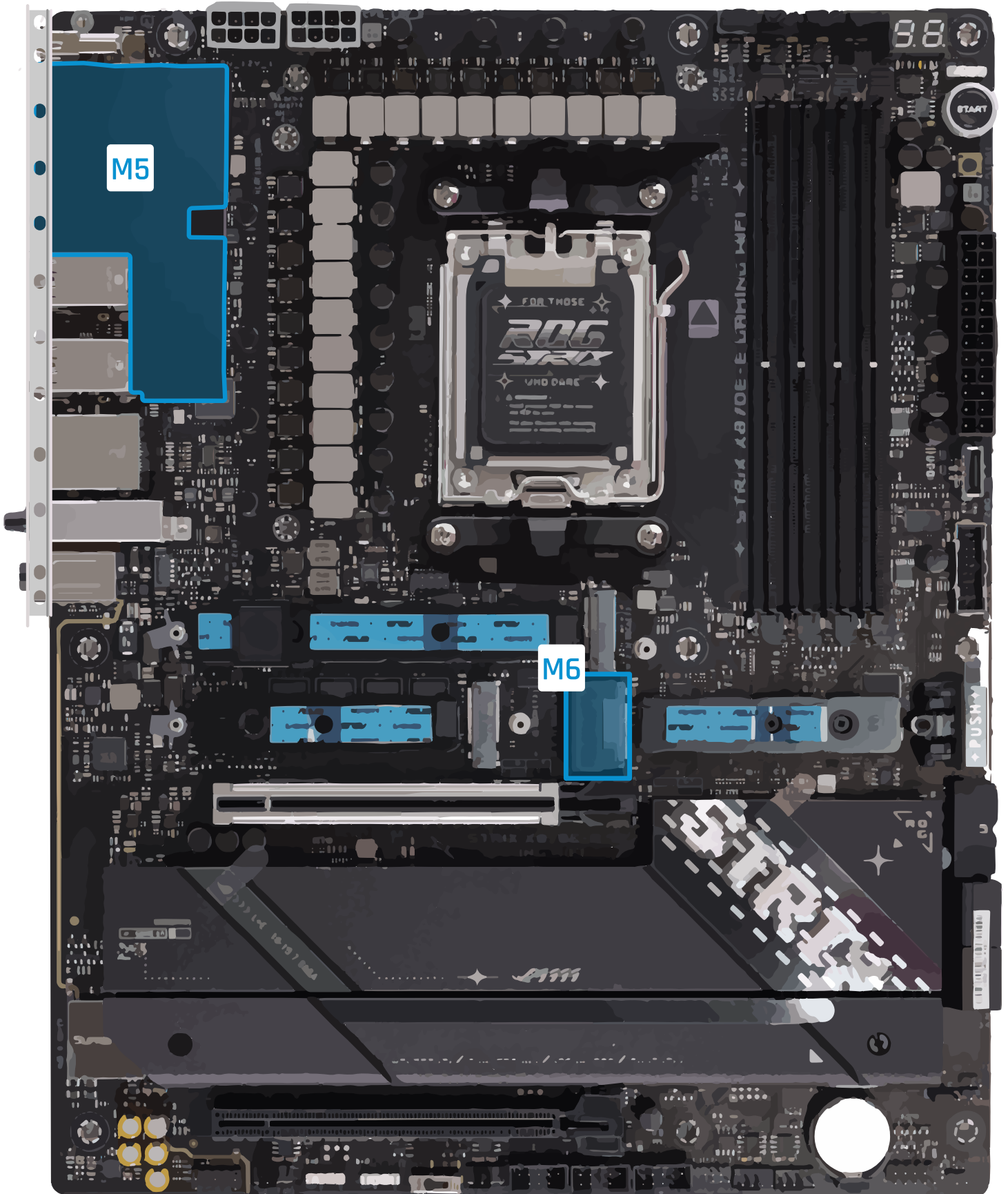

Turn the mainboard and loosen the 2 screws of the M5 and M6 components.

Mainboard drehen und jeweils die 2 Schrauben der Bauteile M5 und M6 lösen.

Tournez la carte mère et desserrez les 2 vis des composants M5 et M6.



Check whether all components M1 - M6 have been removed. The mainboard is now ready for mounting the monoblock.

Überprüfen ob alle Bauteile M1 - M6 demontiert wurden. Das Mainboard ist nun bereit für die Montage des Monoblocks.

Vérifiez que tous les composants M1 à M6 ont été retirés. La carte mère est maintenant prête pour le montage du monobloc.



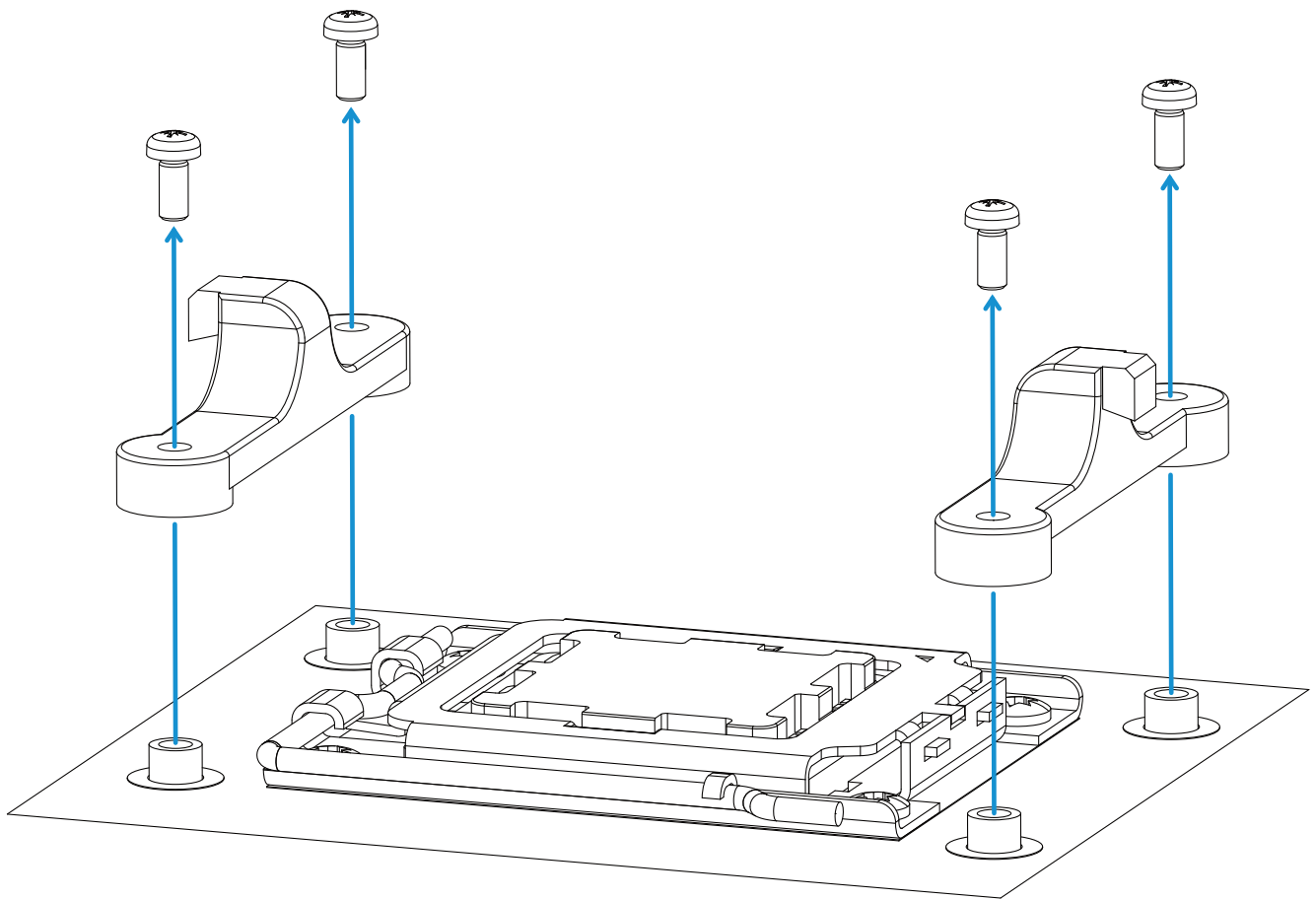

Remove the protective film before installing the M.2 SSD. Use the mainboard manual for details.

Vor der M.2 SSD Installation Schutzfolie entfernen. Für Details das Handbuch des Mainboards benutzen.

Retirez le film protecteur avant d'installer le disque SSD M.2. Pour plus de détails, consultez le manuel de la carte mère.

1

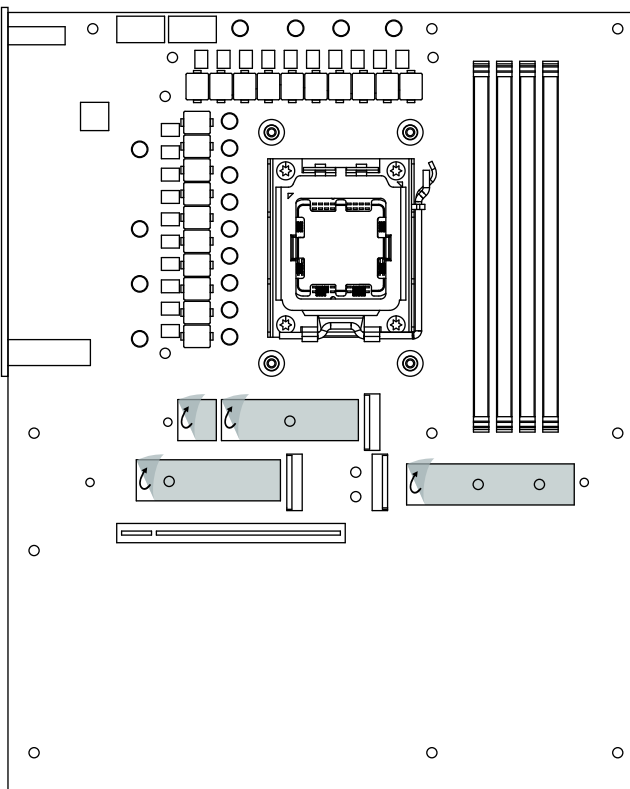

2

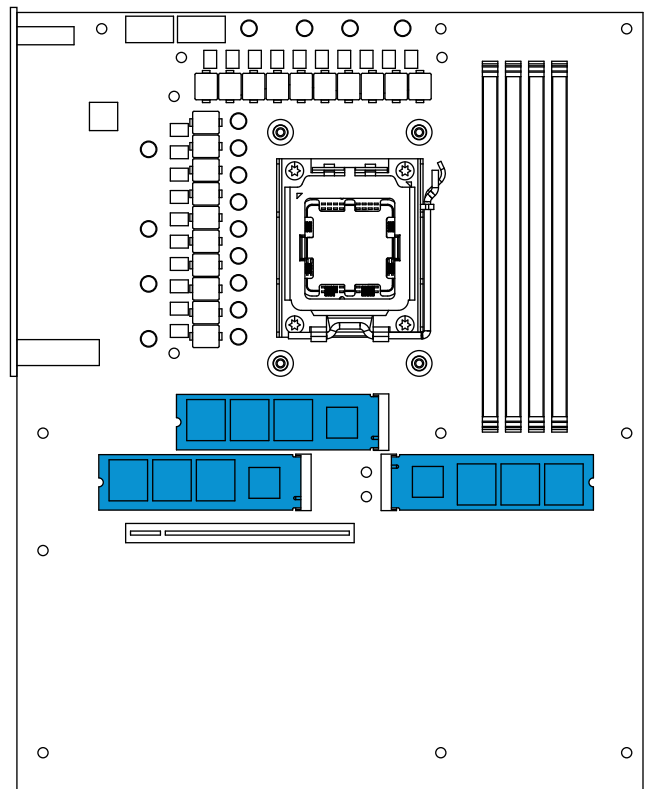

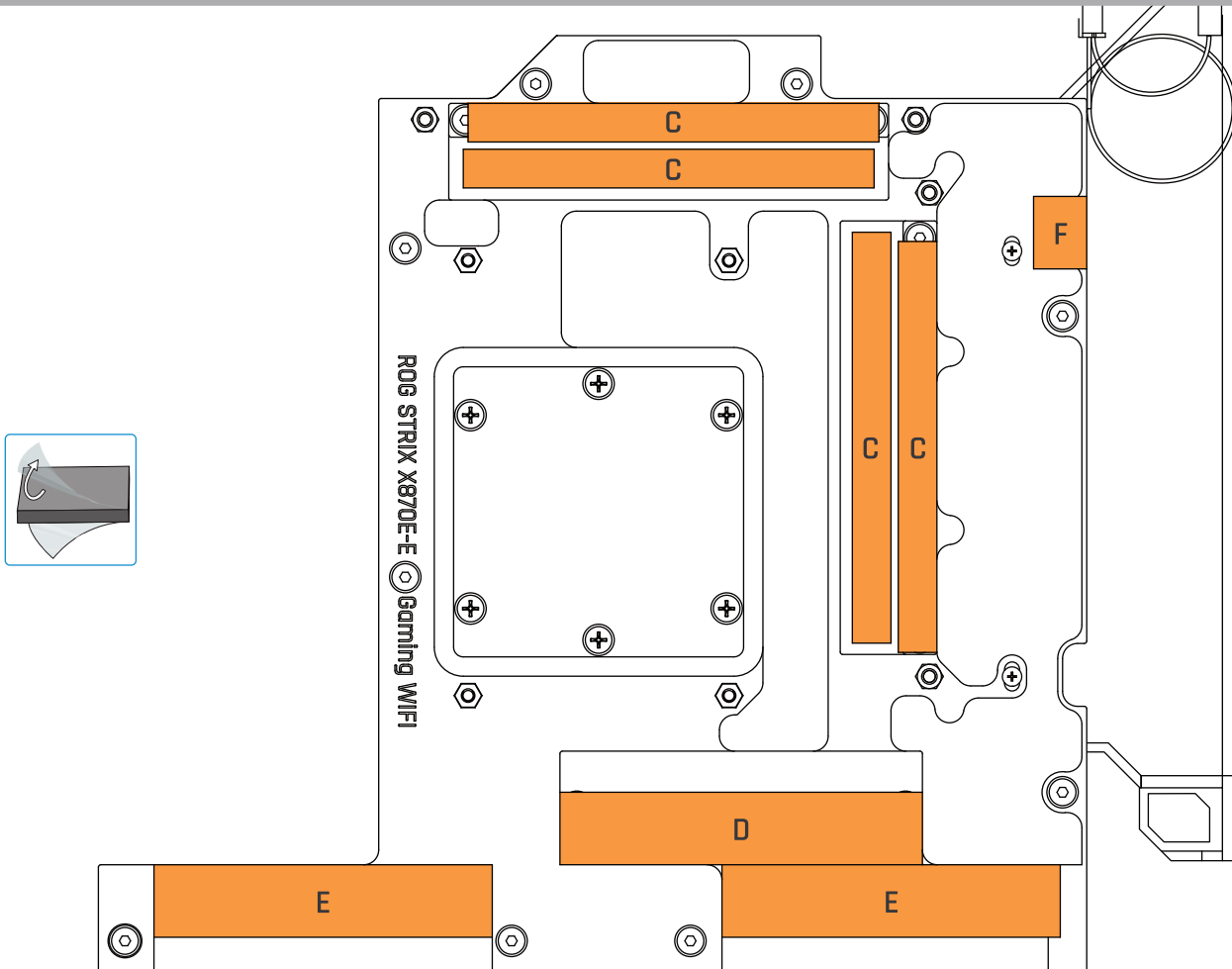
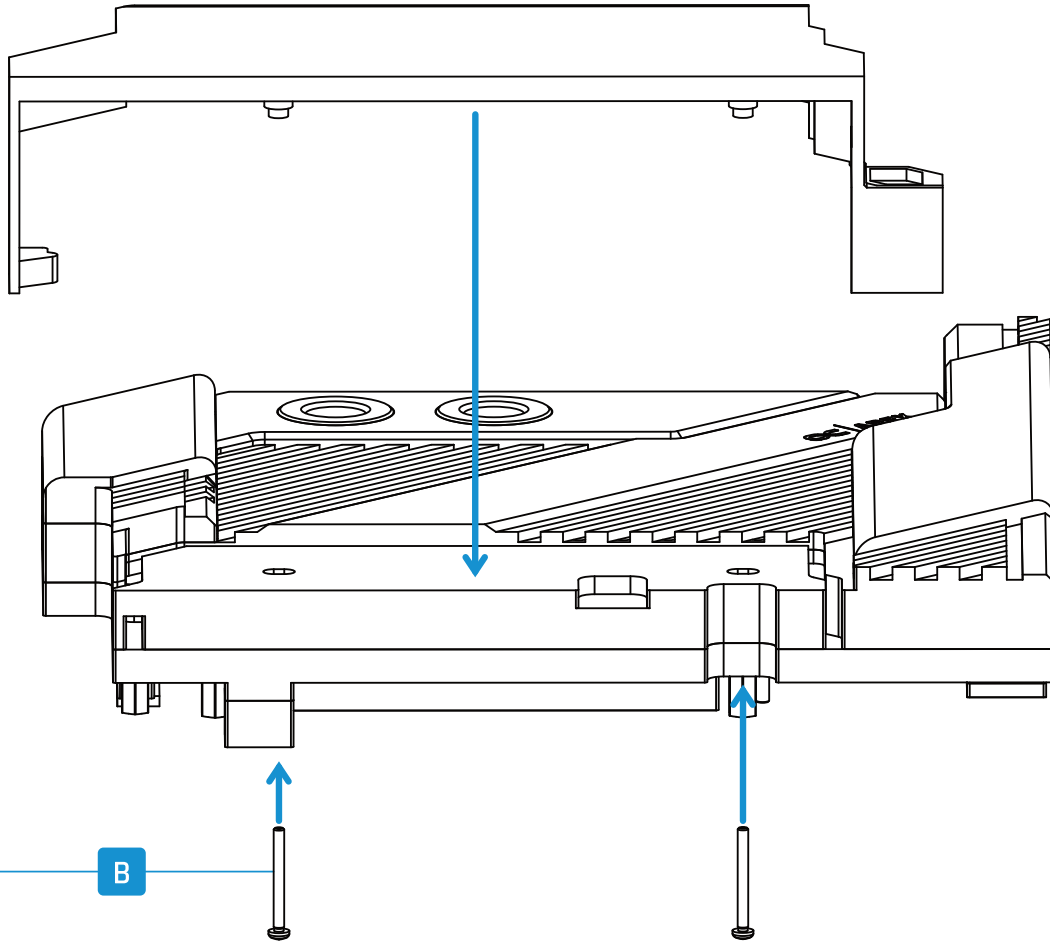

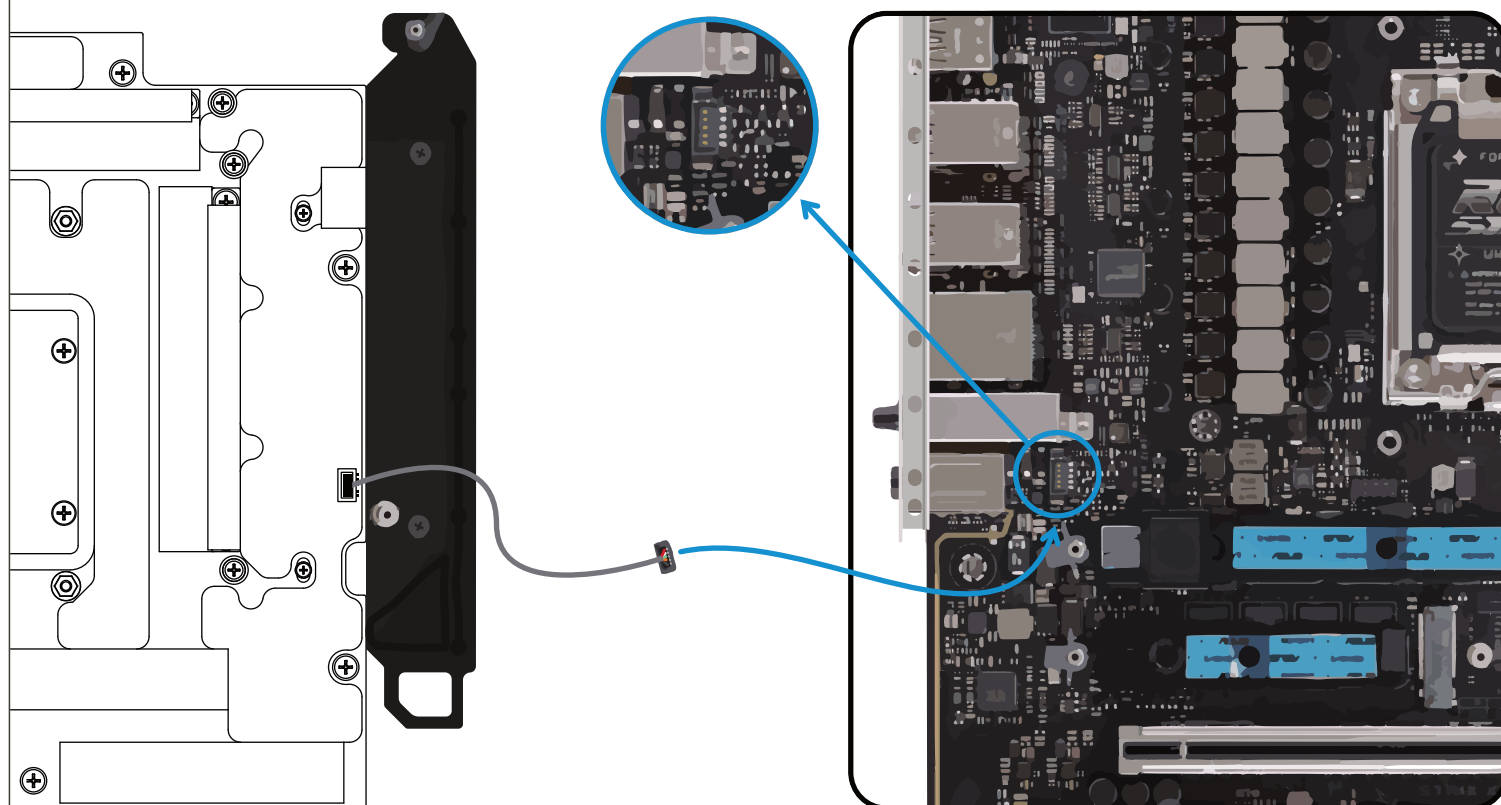
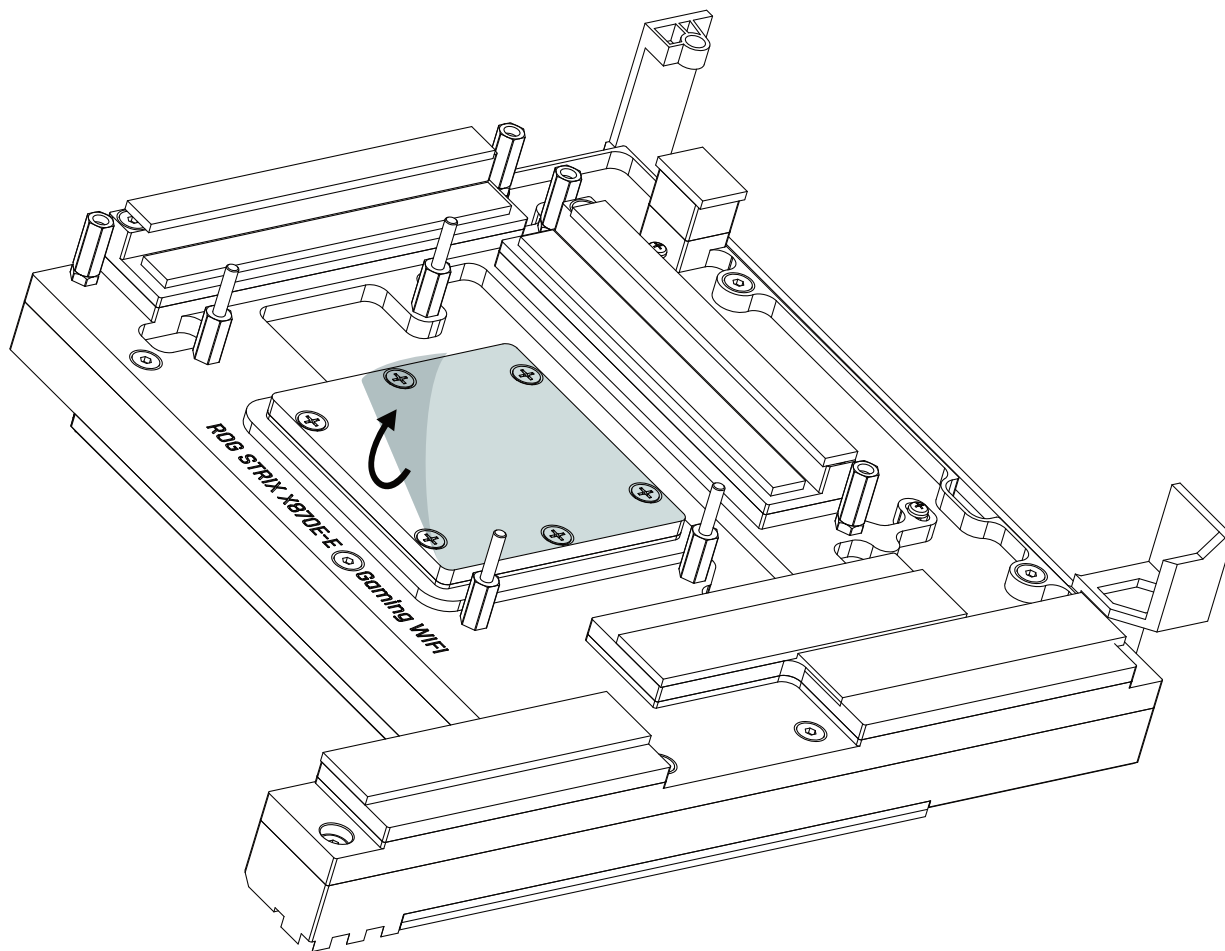

1

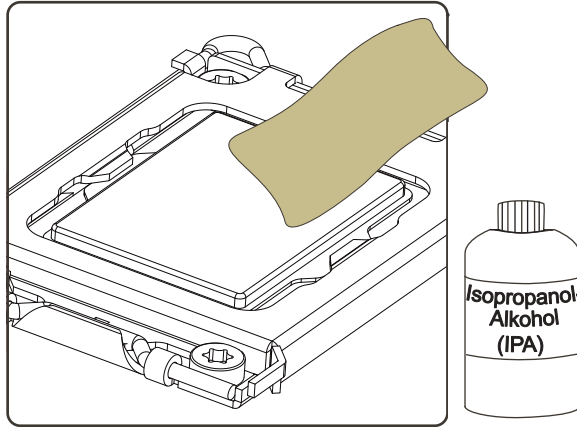

2

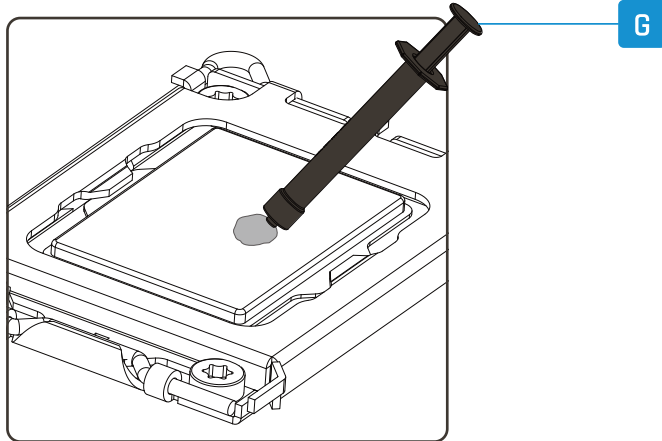

3

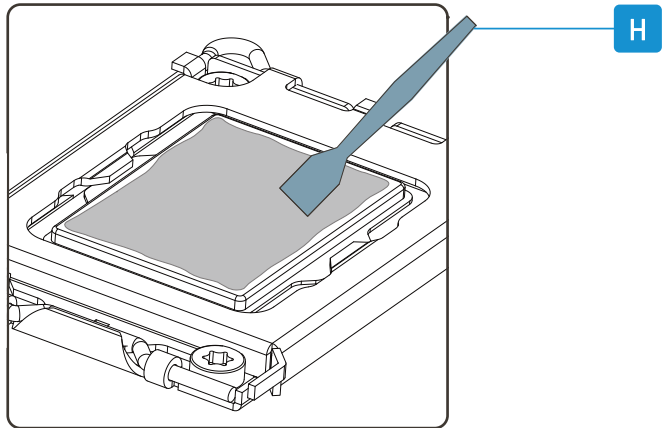

1

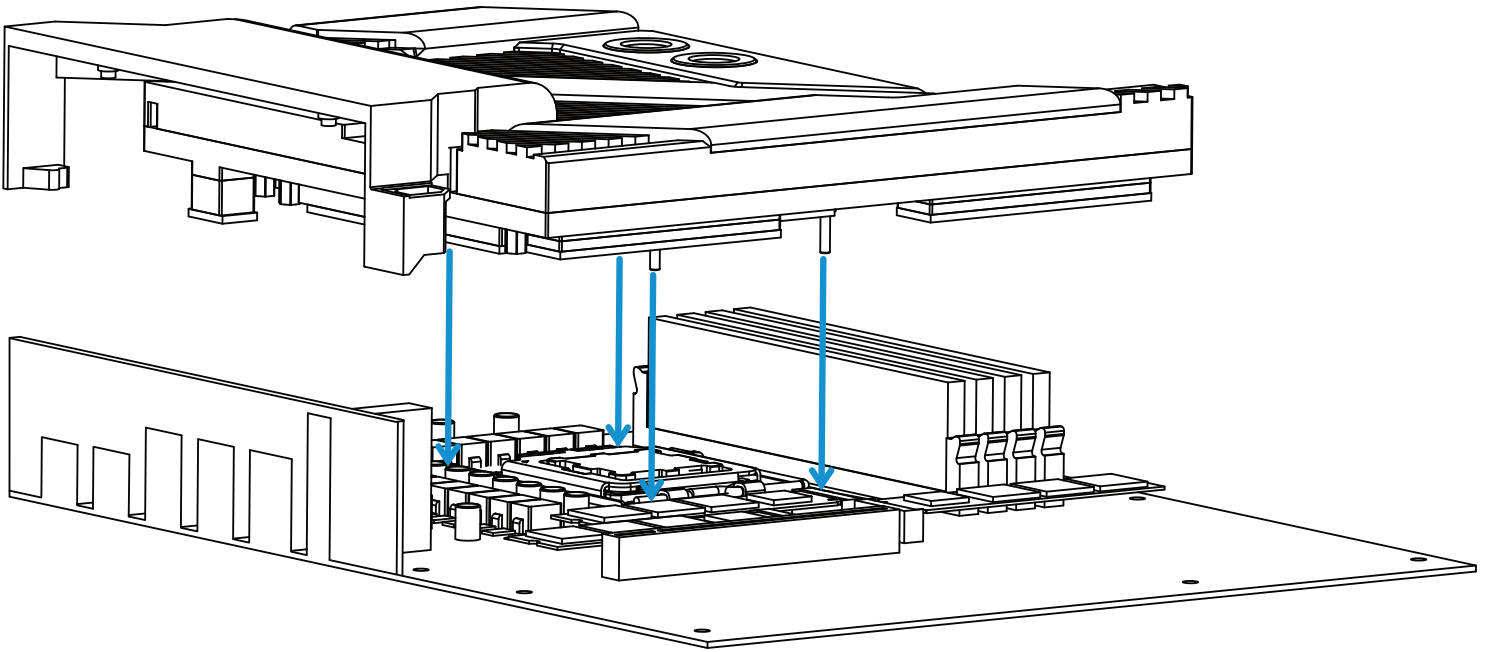

2

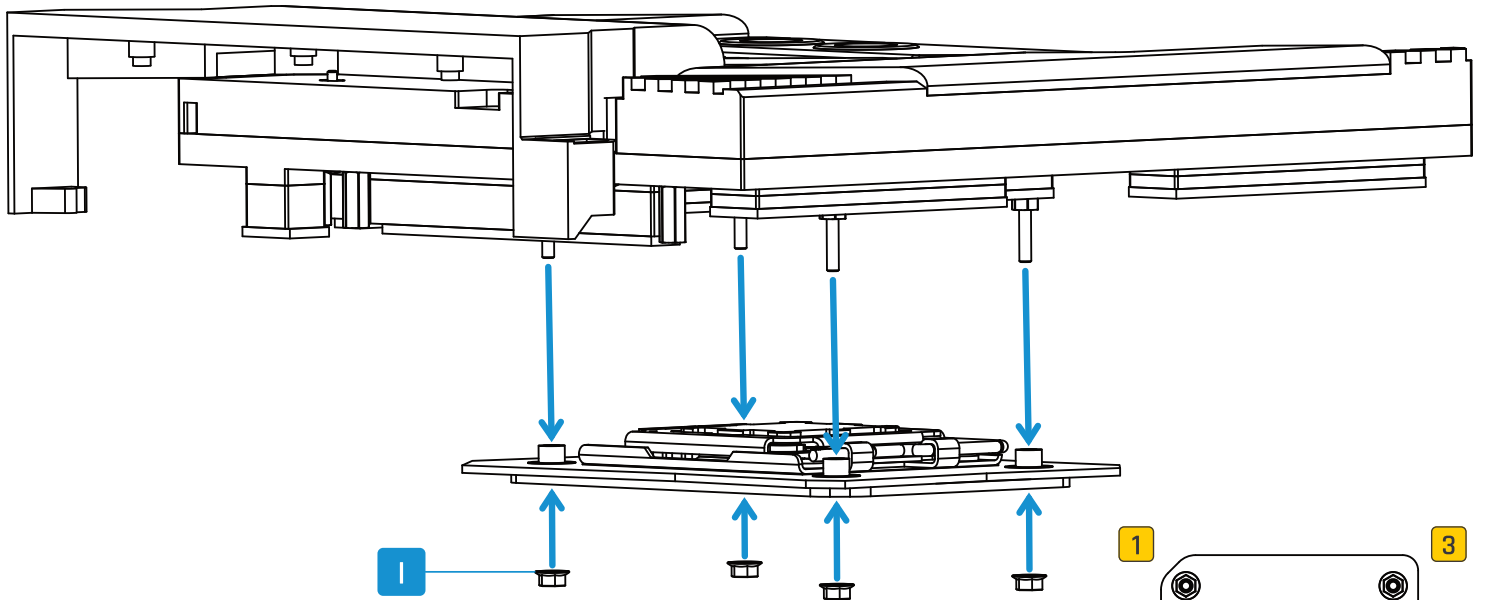

1

1

3

4

2

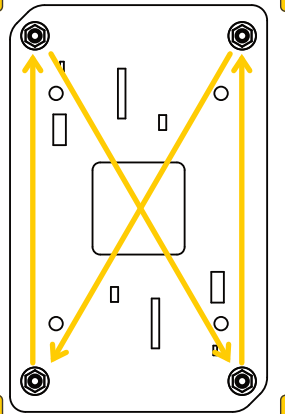

 Hex nut 5mm
 0,27 Nm

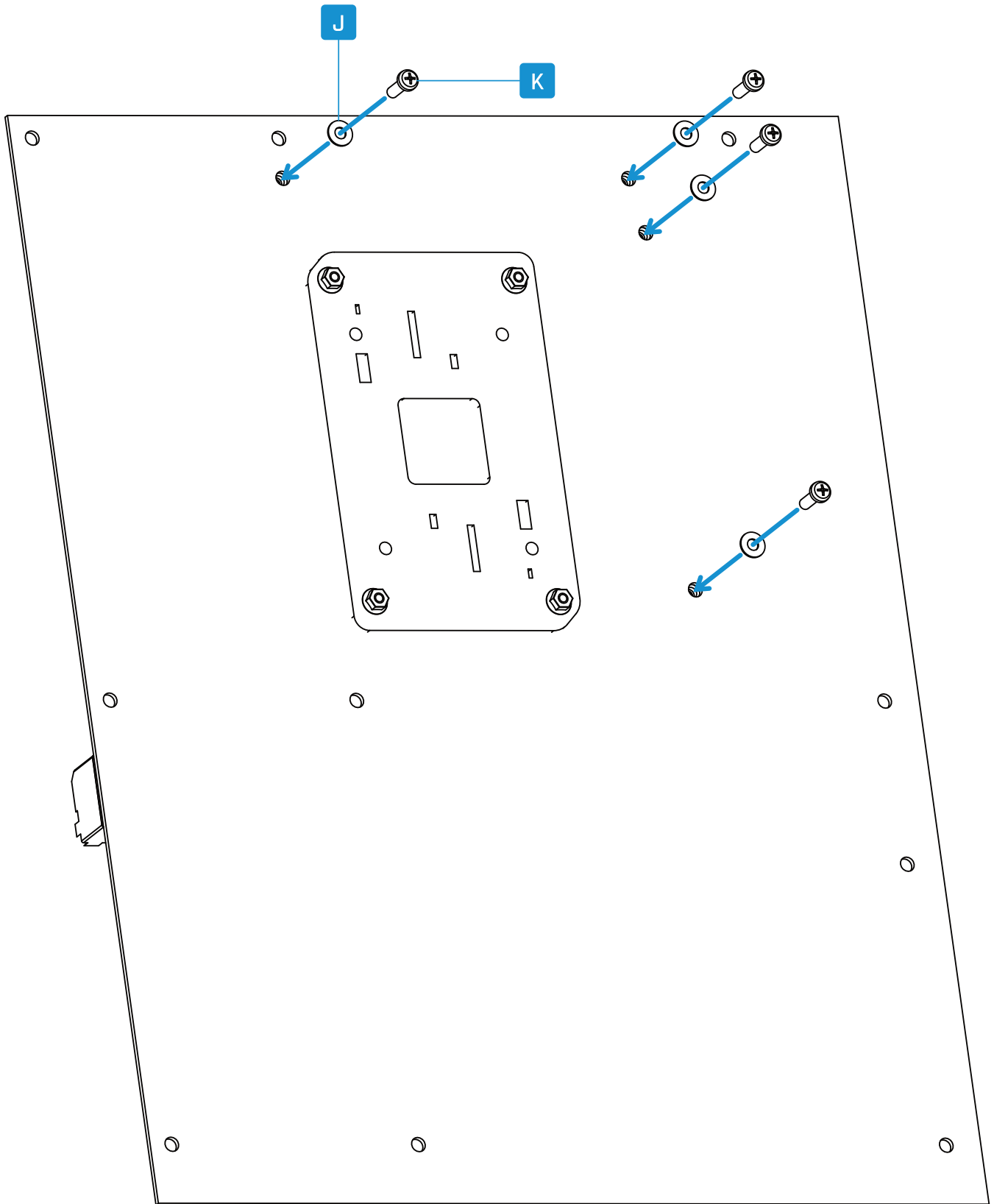

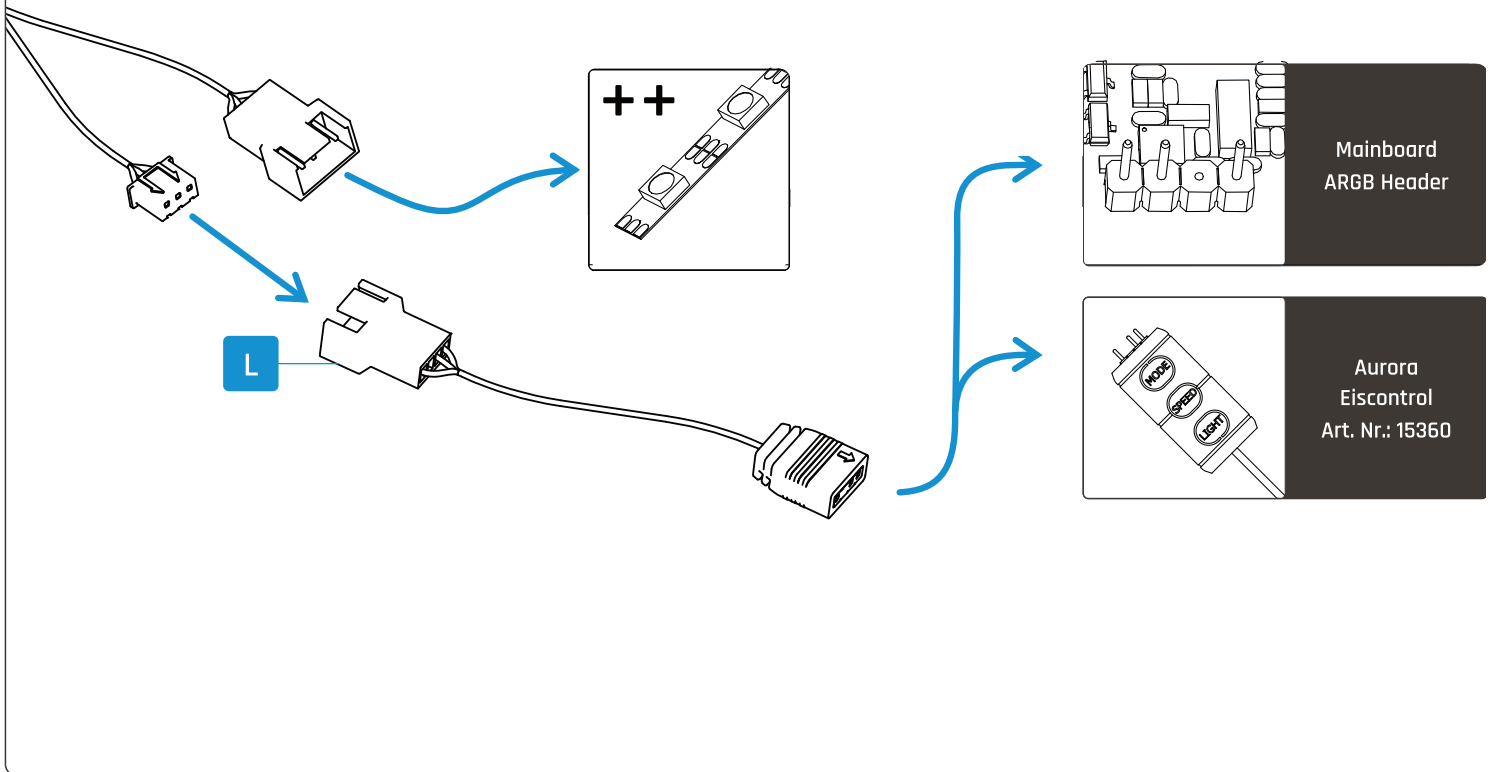

Need help?



Alphacool International GmbH
Marienberger Str. 1
D-38122 Braunschweig
Germany

Support: +49 (0) 531 28874-0
Fax: +49 (0) 531 28874 - 22
E-Mail: info@alphacool.com
<https://www.alphacool.com>

We care!