



# ENTERPRISE SOLUTIONS.

Updated: 2023

AlphaCool International GmbH, Marienberger Straße 1, 38110 Braunschweig, Germany





# Index.

Moore's law	3	Special services	12
Alphacool history	4	OEM	14
Water cooling	5	Overall services	15
The range of water cooling	6	Alphacools partners	17
6 reasons for water cooling	7	Contact	18
Alphacool's solutions	11		

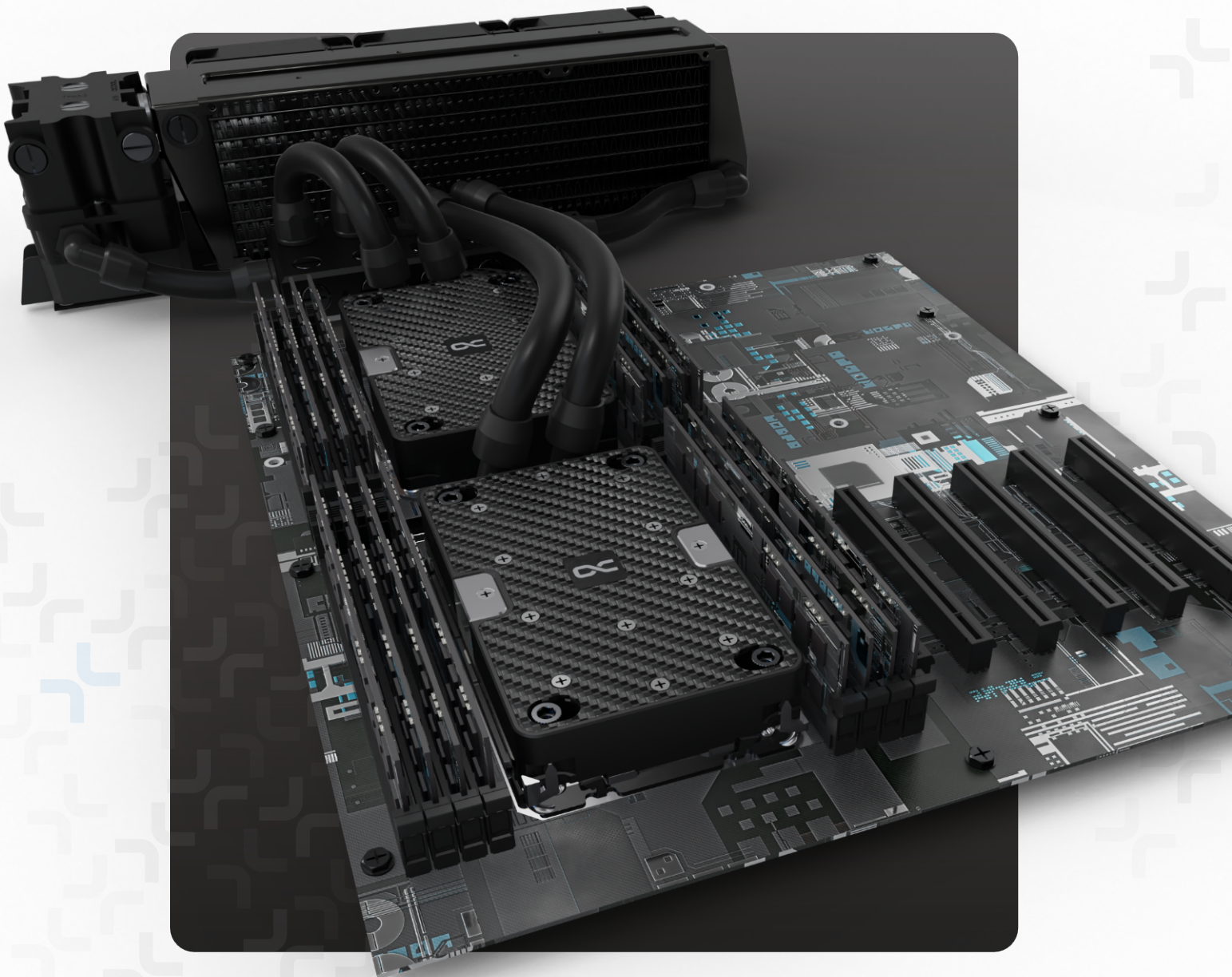



# Moore's law.

**Moore's law** is the observation that the number of transistors in a dense integrated circuit (IC) doubles about every two years.

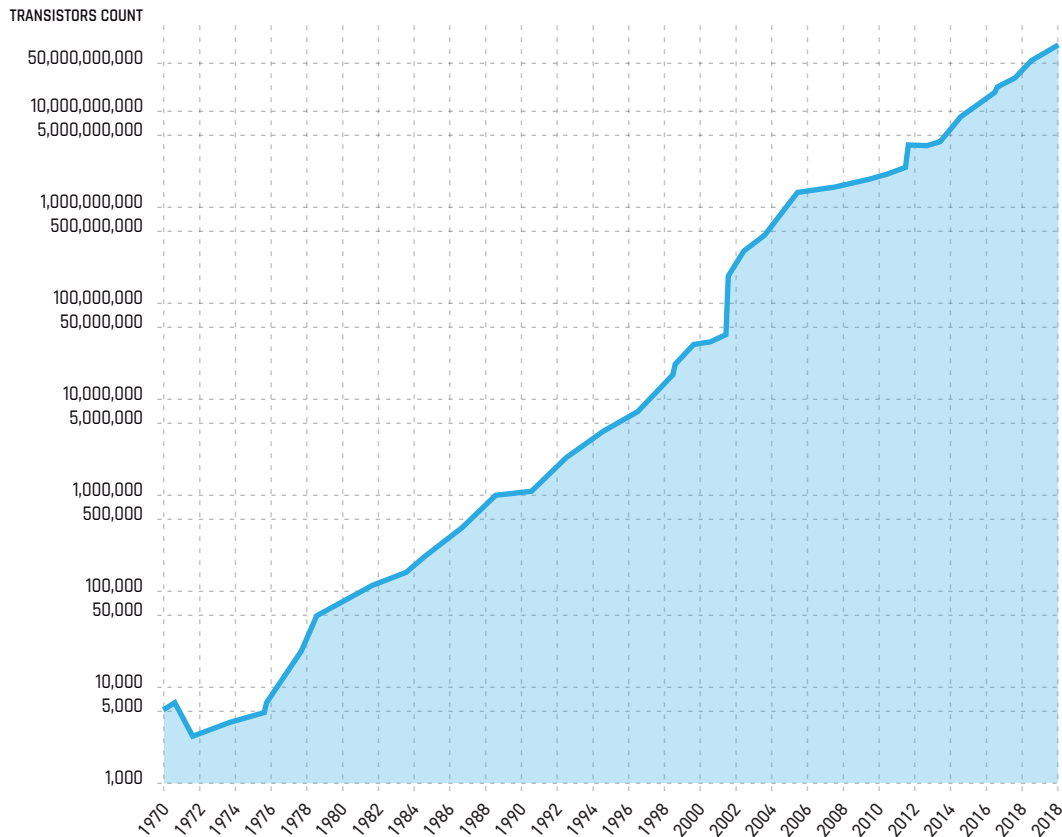

In a dense IC, the number of transistors packed into a small space can generate a significant amount of heat. This heat can affect the performance of the circuit and even cause damage if it gets too high.

As the number of transistors in a PC's integrated circuits continues to increase, so does the heat generated. This has led to the development of various cooling solutions to keep the PC components at a safe operating temperature.

One effective solution is water cooling. Water cooling involves circulating water through a system of pipes and heat sinks, which absorb the heat generated by the PC components. The heated water is then cooled by passing it through a radiator before being circulated back to the heat source.

Compared to other cooling solutions like air cooling, water cooling is more efficient and can dissipate heat more effectively. It also consumes less energy, which can lower the overall operating costs of a PC.

In summary, as the number of transistors in a PC's integrated circuits increases, so does the amount of heat generated. Water cooling is an effective solution to dissipate this heat, and it can also reduce energy consumption and lower operating costs.



# Alphacool history.

Alphacool is a German company that has become a leading provider of liquid cooling solutions for PCs and other electronic devices. Since its founding in 2003 by Andreas Rudnicki, the company has been committed to providing high-quality products and personalized service.

Over the years, Alphacool has expanded its product line to include a wide range of cooling solutions for CPUs, GPUs, motherboards, and other components. The company has also developed a number of innovative technologies, such as the patented Alphacool NexXoS radiators and the Eisblock water blocks, which are known for their excellent performance and reliability.

In recent years, Alphacool has become more and more important in the B2B and server solutions markets. The company's products are used by professionals in a variety of industries, from gaming and video production to scientific research and industrial applications. Alphacool's liquid cooling solutions offer superior performance and efficiency compared to traditional air cooling solutions, making them an ideal choice for demanding server and industrial applications.

Today, Alphacool is a global company with a network of distributors and resellers around the world. The company continues to innovate and push the boundaries of what's possible with liquid cooling, and is a trusted partner for anyone who wants to build a high-performance, reliable, and efficient PC or electronic device. Whether you're a DIY enthusiast or a professional in the B2B or server solutions market, Alphacool has the expertise and experience to help you get the most out of your hardware investment.





# Water cooling.

Water cooling is a popular and effective method of cooling electronic devices such as CPUs and GPUs. By transferring heat away from these components using water, water cooling can **improve performance, increase CPU/GPU density, and extend the lifespan of your devices.**

Additionally, water cooling is more energy-efficient than traditional air cooling methods, **reducing energy consumption and operating costs.** Water cooling can also significantly reduce the noise level of your system, making it an ideal choice for **quiet environments.** Finally, water cooling components can often be reused, **reducing waste** and providing a more sustainable solution for your cooling needs.

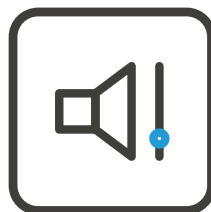
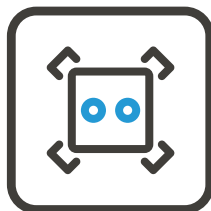
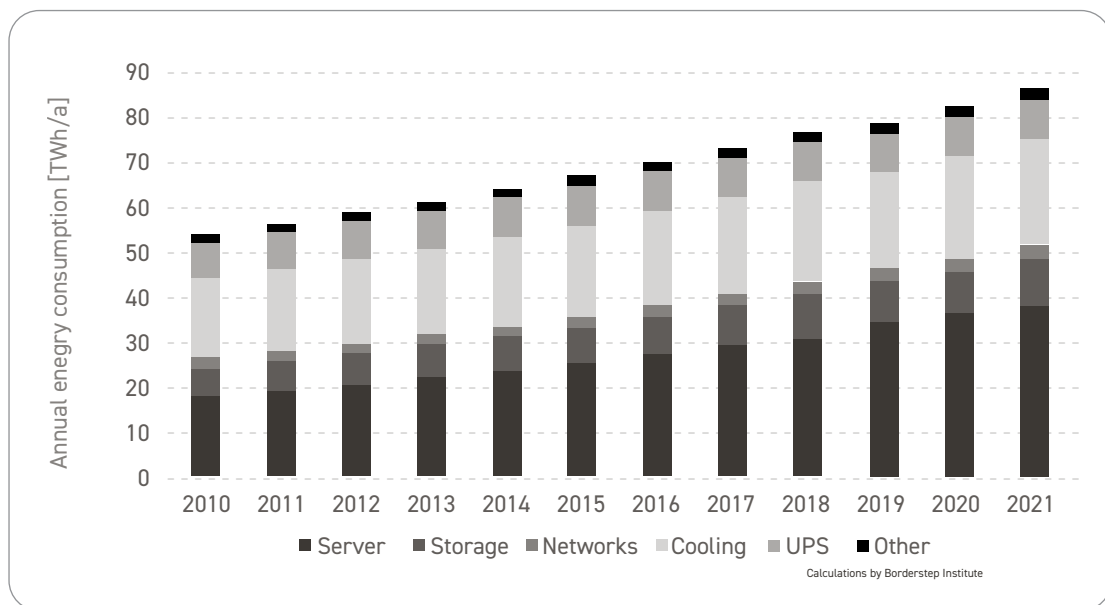



# The range of water cooling.



Water cooling is a commonly used method for cooling machinery and equipment in a variety of industrial sectors. In the **manufacturing industry**, water cooling is used to regulate the temperature of machinery such as **injection molding machines, extruders, and presses**. This helps to maintain a stable operating temperature and prevent overheating, which can cause damage to the equipment and reduce its efficiency.



In the **energy sector**, water cooling is used in **power plants** to cool the steam used to generate electricity. The steam is first passed through a condenser, which is cooled by water circulating through a series of tubes. This allows the steam to condense back into water, which can be used again in the power generation process.



Water cooling is also used in the **transportation industry** to cool engines and transmissions in **automobiles and airplanes**. This is because these systems generate a lot of heat during operation, which can cause damage and reduce their efficiency. By circulating cool water through these systems, the heat can be absorbed and carried away, helping to maintain a stable temperature and prevent damage.



In the **computing industry**, water cooling is used to cool high-performance computing systems such as servers and **data centers**. This is because these systems generate a lot of heat during operation, which can reduce their performance and lifespan. Water cooling systems work by circulating cool water through a series of tubes that are in contact with the hot components of the computing system. This allows the heat to be absorbed and carried away, helping to maintain the system's performance and reliability.



Water cooling is also used in the **chemical industry**, where it is used to cool and condense vapors in various chemical processes. In the **food and beverage industry**, water cooling is used to cool products such as beer and soft drinks during the **manufacturing process**.



In **medicine**, water cooling is used in a variety of applications. For example, in medical imaging such as magnetic resonance imaging (MRI), water is used to cool the magnets that produce the images. This helps to maintain a stable temperature and ensure accurate imaging.



Water cooling is also used in **surgery**, where it is used to **regulate the temperature of the patient's body** during certain procedures. This can help to prevent overheating, which can be dangerous and lead to complications. Additionally, water cooling can be used to **cool surgical instruments** during procedures, which can help to reduce tissue damage and improve outcomes.





# 6 reasons for water cooling.

„ ...As more liquid-cooled servers are deployed, the average cost of liquid-cooled data center design is lower, and in turn, the greater the cost benefits for operations and maintenance. PUE is reduced by 0.25 (air-cooled PUE1.4, liquid-cooled PUE1.15), and data center energy consumption is cumulatively reduced by more than 27 percent (liquid-cooled data center vs. air-cooled data center)... “

Jay Zhang

Vice President bei Inspur Global Business und CEO von Inspur Europe

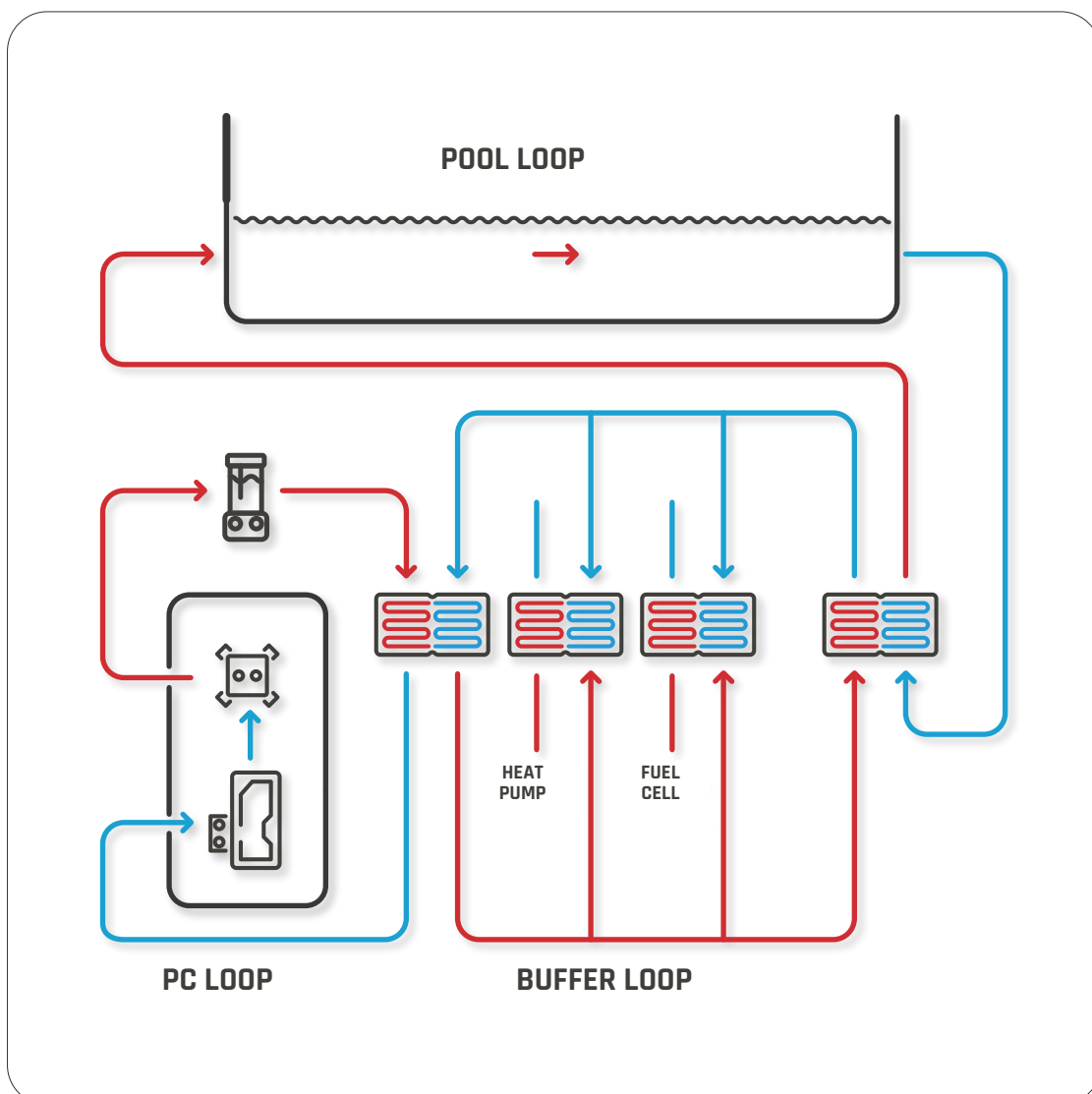

Alphacool is actively working on the research and development of water to water cooling systems to provide even more efficient cooling performance than traditional water cooling solutions, which already provide superior heat dissipation compared to air cooling.

By circulating water between two separate cooling loops, these systems have the potential to achieve unprecedented levels of cooling power, resulting in greater stability and performance for demanding computing applications.



# 6 reasons for water cooling.

## 1. Energy efficiency:

Water has superior physical properties compared to air, specifically its specific heat capacity which is better than any other fluid or gas on earth. This means that water is much more efficient at transferring heat. In fact, one liter of water can remove 3000 times more energy from a system compared to one liter of air. This is because air has poor heat conductivity.

Air requires fast and turbulent flow, a large surface area for interaction, and increased blow pressure to effectively cool. However, these factors increase air resistance and require more power. In contrast, watercooling is superior to air cooling because of its higher cooling power.

	Air	Water
Needed volumetric flow Liter/s	33.000	11
Specific heat capacity kJ/(kg·°C)	1,0	3,6

## 2. Water cooling's footprint is smaller in size:

A water cooling system requires less space than an air cooling system due to water's superior heat capacity, which allows for smaller cooling components. This makes it possible to design water-cooled devices that are more compact than their air-cooled counterparts.

Additionally, water cooling systems are typically compact and can fit inside a standard cabinet. On the other hand, air cooling systems may require a separate room for air handling and numerous air ducts, taking up more space. For instance, a water-cooled unit can be 50% smaller than an air-cooled one, or a similarly-sized air-cooled unit may have only 66% of the nominal power of a water-cooled unit.

## 3. Energy savings:

Air cooling systems rely on fans to move a large volume of air to cool the system. These fans require a significant amount of electrical energy to operate. On the other hand, water cooling systems use pumps to circulate a smaller volume of coolant liquid to cool the system. The pumps require less electrical energy than fans to perform the cooling function.

The difference in electrical energy consumption between air and water cooling systems is significant, with water cooling systems requiring less than 10% of the energy required by comparable air cooling systems. This is particularly important in battery systems, where the cooling energy is drawn from the battery itself.





# 6 reasons for water cooling.

## 4. Water cooling is silent:

Another benefit of water cooling systems is that they can provide a quieter work environment when compared to air-cooled systems. This is because air-cooled systems typically use fan motors to dissipate heat, which can generate a significant amount of noise. In contrast, water-cooled systems use liquid coolant to transfer heat away from components, which results in quieter operation.

Drive cooling type	Frame size	Nominal power P <sub>n</sub> (kW)	Coolant flow rate (m <sup>3</sup> /h)	Noise level dB(A)
Air	4 U	2000	5200	76
Air	5 U	2800	6500	77
Air	6 U	3200	7800	78
Water	4 U	3000	3,84	69

## 5. Water cooling is extremely robust:

Water cooling systems have been increasingly adopted by various industries for their superior cooling performance and efficiency. One of the key advantages of a water cooling system is that it is a closed system, which means that it is not affected by external factors such as dirt or dust. This ensures that the cooling capacity and availability of the system remain consistent over time, without any degradation.

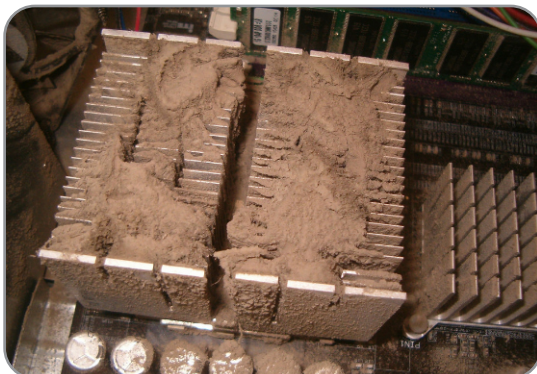



# 6 reasons for water cooling.

## 6. Water cooling is number 1:

Using liquid cooling in place of air-conditioning systems can be highly beneficial, as it eliminates the need for additional equipment and reduces installation and operational costs. This is because air-conditioning systems typically require additional devices and air ducts, which can make the installation process more complicated and costly.

Unlike air cooling systems, which have built-in filters that must be periodically cleaned or replaced, liquid cooling systems do not require filters as they are closed systems. This can greatly simplify maintenance efforts and reduce costs associated with filter replacement.

When selecting a cooling solution, it is important to consider the specific application and environmental conditions. However, it is clear that water cooling offers significant advantages in many critical applications. These advantages include a smaller required footprint, improved energy efficiency, and lower maintenance requirements. Additionally, water cooling systems are highly reliable and can provide long-term benefits for both system integrators and end-users.

Overall, the use of liquid cooling systems provides a cost-effective and reliable alternative to traditional air conditioning systems, making it an attractive option for many different applications.



# Alphacool's solutions.

Our company specializes in providing cutting-edge water cooling technology to other businesses. By using water cooling, companies can keep their processors at optimal temperatures without the need for energy-intensive air conditioning, resulting in significant energy savings and lower costs.

Our water cooling systems are designed to be efficient, reliable, and easy to install. We work closely with our clients to ensure that our systems are tailored to their specific needs and requirements, providing them with a solution that is both cost-effective and environmentally friendly.

We believe that our water cooling technology not only benefits our clients by reducing their energy costs and carbon footprint, but also has a positive impact on the environment by helping to combat climate change and preserve natural resources.

As a responsible business, we are committed to providing our clients with high-quality, sustainable solutions that meet their needs while also being mindful of our impact on the environment.

We believe that by working together, we can create a more sustainable future for all.

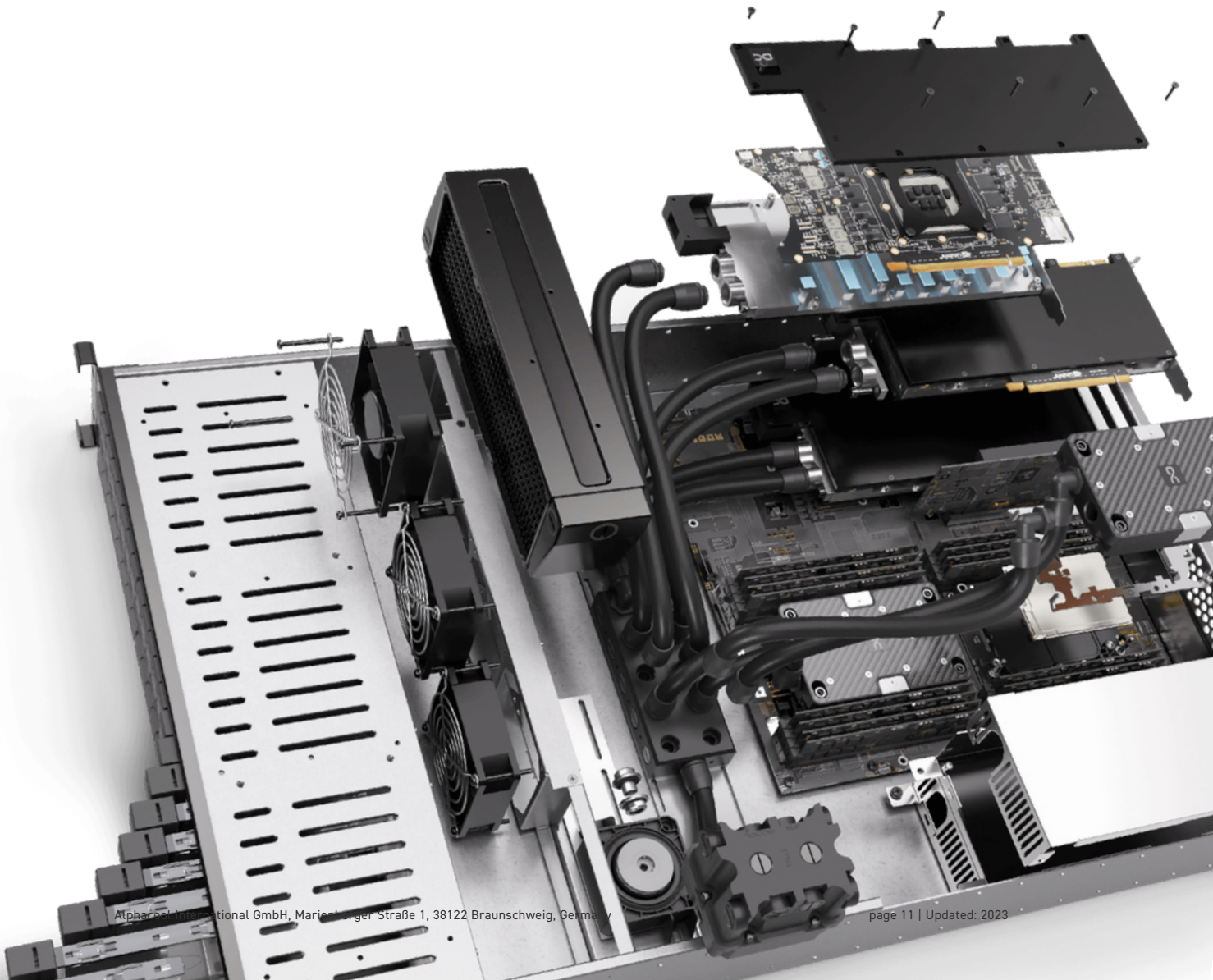



# Special services.



As part of our commitment to providing high-quality services, we offer a special service to our clients where we create individual 3D drawings and samples to help them present their ideas visually to partners and customers.

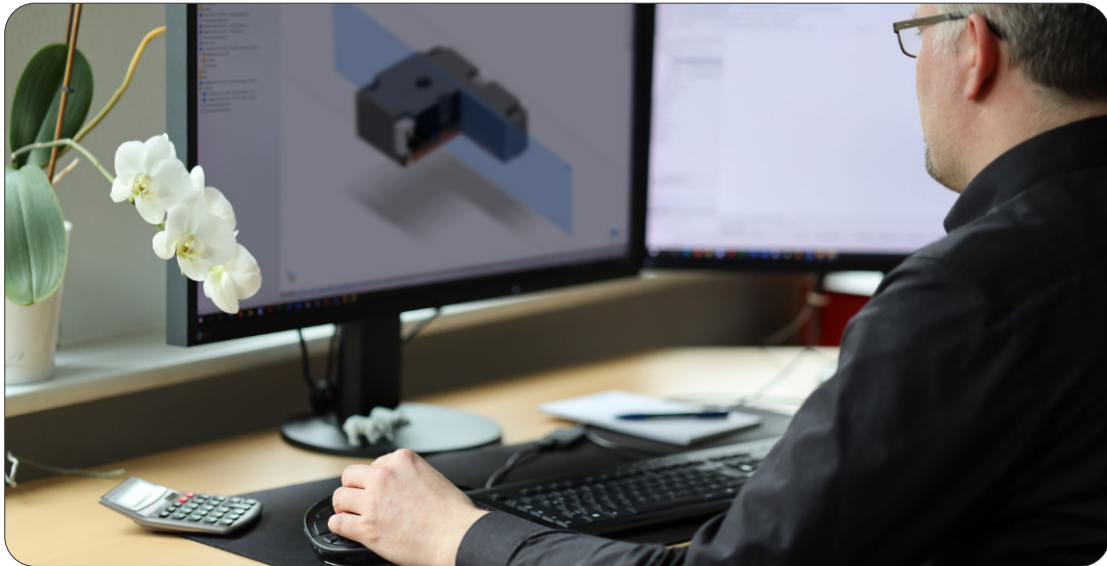

Our team of experienced designers and engineers work closely with our clients to understand their needs and requirements, creating 3D models that accurately represent their vision. These models can be used for a variety of purposes, from showcasing product designs to testing prototypes and identifying potential issues before production.

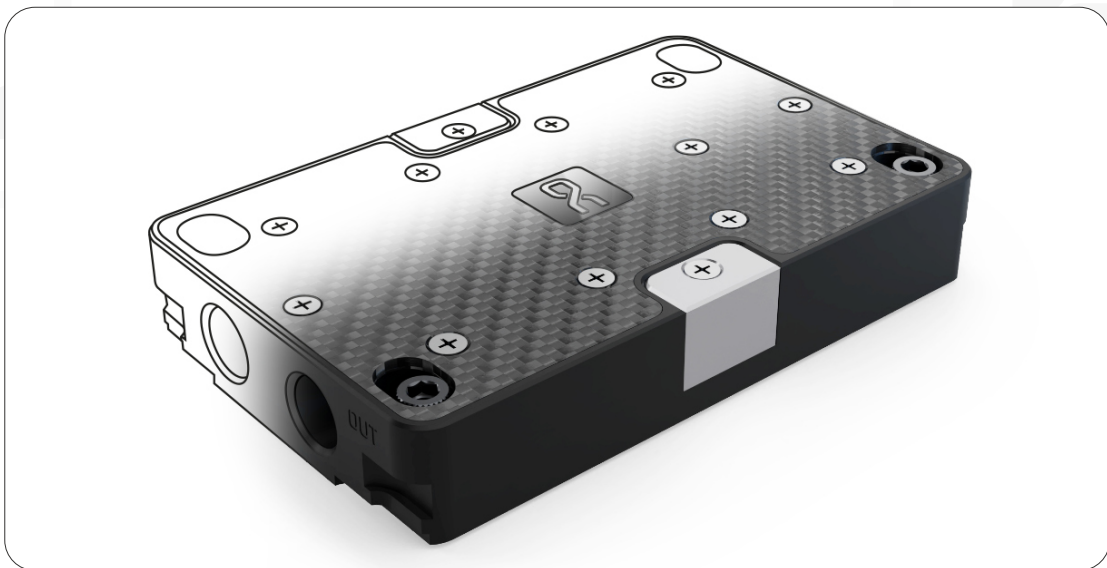



# Special services.



In addition to 3D drawings, we also provide our clients with physical samples of their designs. This allows them to see and touch their product in real life, providing a more tangible representation of their vision. These samples can be used for presentations, trade shows, or even as a way to test the product in a real-world environment.

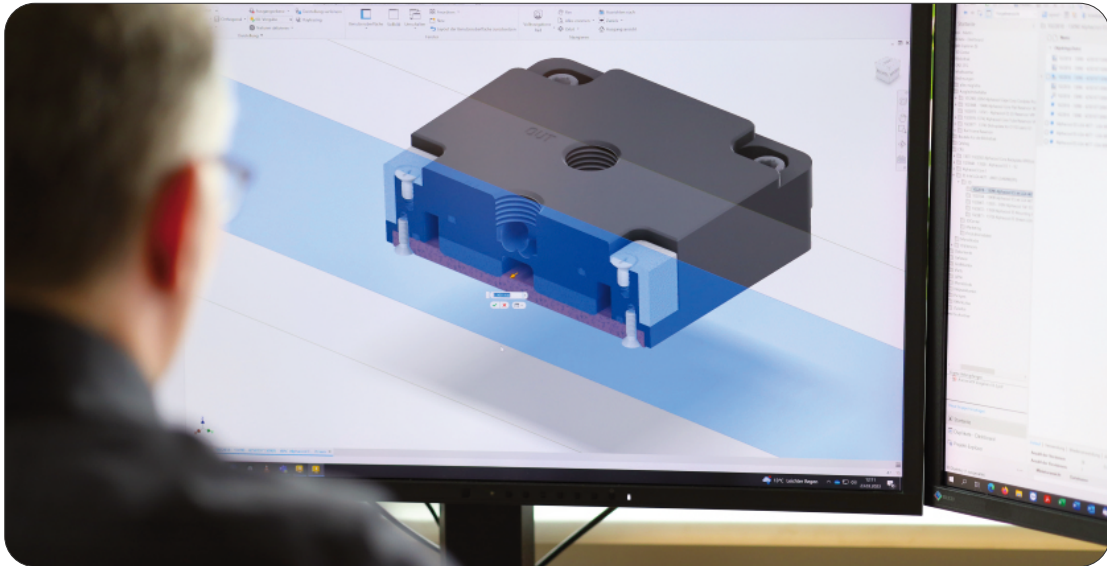

We believe that our 3D drawing and sample service not only benefits our clients by helping them to present their ideas in a more engaging and effective way, but also provides them with a cost-effective and efficient way to test and refine their designs before production. We are able to provide a service that is both customized and scalable, ensuring that our clients are always satisfied with the end result.

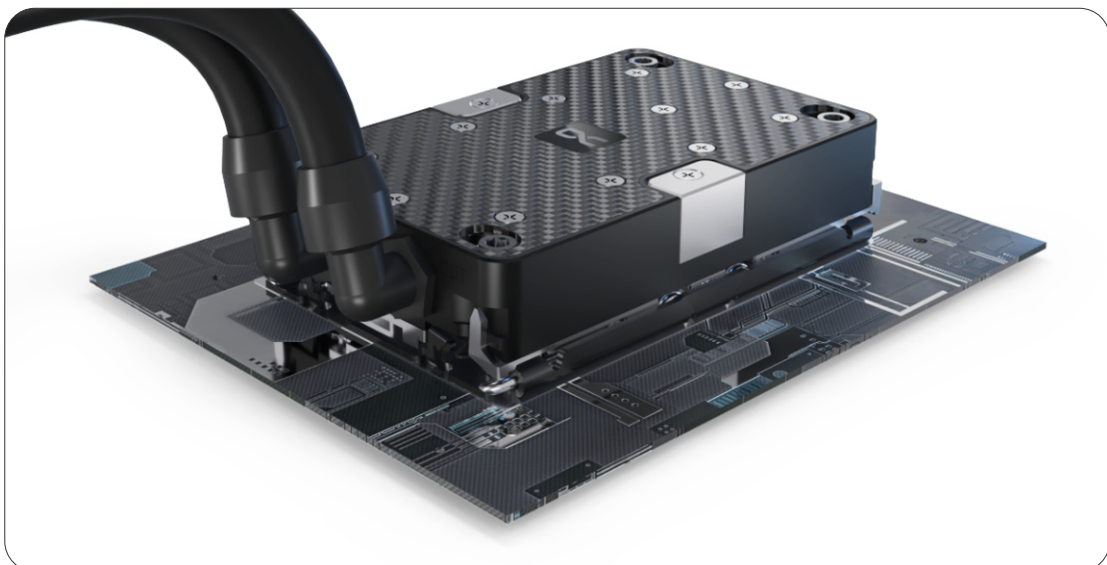

# OEM

Alphacool is a well-known brand in the PC water cooling industry. In addition to offering a wide range of products for consumers, Alphacool also offers Original Equipment Manufacturer (OEM) services for companies looking to incorporate liquid cooling solutions into their products. With a team of experienced engineers and a state-of-the-art production facility.

Alphacool can provide customized liquid cooling solutions that meet the specific needs of their OEM customers. From design and prototyping to mass production and quality control, Alphacool is equipped to handle every stage of the OEM process, ensuring that their customers receive high-quality and reliable liquid cooling solutions.

Alphacool has worked with a variety of customers to provide custom liquid cooling solutions as an OEM.

Some notable examples include manufacturers of high-performance gaming PCs, custom computer builders, and companies like Medion, fractal design, Asus, Sapphire, be quiet and Cooler Master.

Alphacool's expertise in liquid cooling technology and ability to customize solutions has made them a trusted partner for these and many other companies seeking reliable and efficient cooling solutions for their products. Alphacool's OEM services provide tailored solutions that meet the unique needs of their customers.





# Overall services.

Our company provides cost-effective cooling solutions for a variety of hardware components, including servers, workstations, and gaming systems. We understand that performance issues can arise due to overheating, which is why we offer solutions that are tailored to your specific needs and hardware configuration.

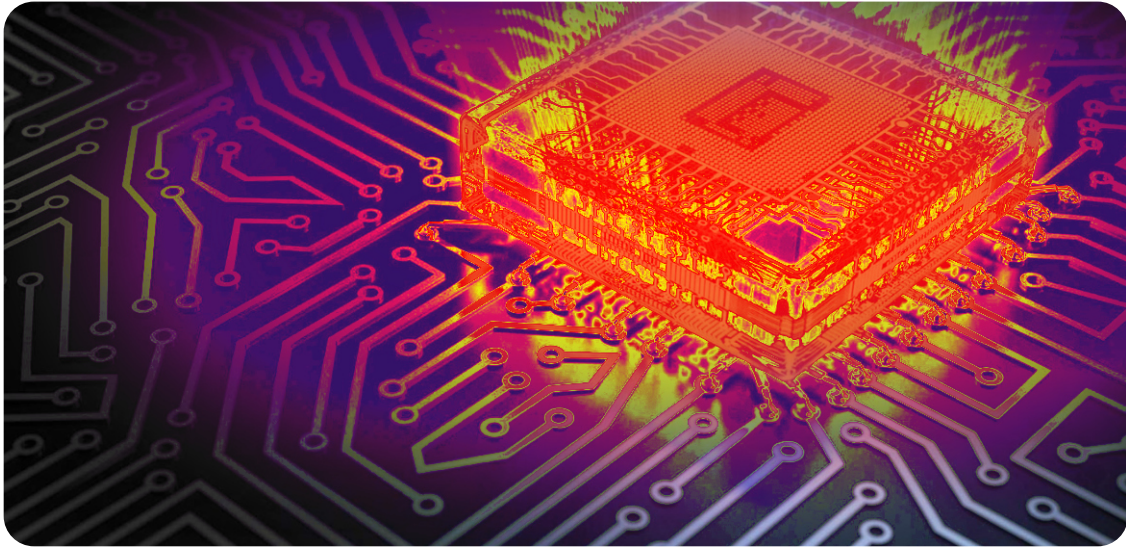

Our experienced team can help you choose the right cooling solution for your specific case, taking into account the size and type of your housing, the components you're using, and other factors. We also offer a range of products that are specifically designed to work with certain hardware configurations, ensuring that you get the best possible performance from your system.





# Overall services.

In addition to providing cooling solutions, we also offer support and assistance to our clients. We provide detailed instructions and manuals whenever possible, and can even send you physical samples if you need them. Our support team is always available to help you with any issues that arise, whether it's a factory defect or a problem with installation or operation.

If something does go wrong, you can count on us to make it right. Our support team is available by email or phone, and we'll work with you to diagnose and fix any issues. If necessary, we can also accept returns and perform internal testing to identify and fix any problems.

Whether you're building a server for personal use or managing an industrial or B2B system, our cooling solutions and support services can help you get the most out of your hardware investment. Contact us today to learn more about our products and services.







# Alphacool partners.

Qualcomm



wingtra



NEWCRAFT





# Contact

**Alphacool International GmbH  
- Headquarter**

Marienberger Str. 1  
38122 Braunschweig, Germany  
Tel: +49 (0) 531 28874 - 0  
Fax: +49 (0) 531 28874 - 22  
info@alphacool.com

**Alphacool International GmbH  
- Team FRANCE**

23 rue de l'avenir - lot 219  
14650 Carpiquet  
France  
Tel: +33 (0) 6 88 03 54 09  
g.montenard@alphacool.com

**Alphacool International GmbH  
- Team Berlin**

Ansbacher Str. 5  
10787 Berlin, Germany  
Tel: +49 (0) 5207 95846 - 016  
enterprise@alphacool.com

**Geschäftsführer:**

Andreas Rudnicki, Fabian Noelte

**Gerichtsstand:**

Amtsgericht Braunschweig  
HRB 202390

**Steuernummer:**

13/207/02047

Finanzamt Braunschweig

**USt.-IDNr. gem. §27a UstG:**

DE270458421

