

Alphacool Eisblock Aurora Geforce RTX 4070 TI Eagle OC with Backplate

Alphacool article number: 13729

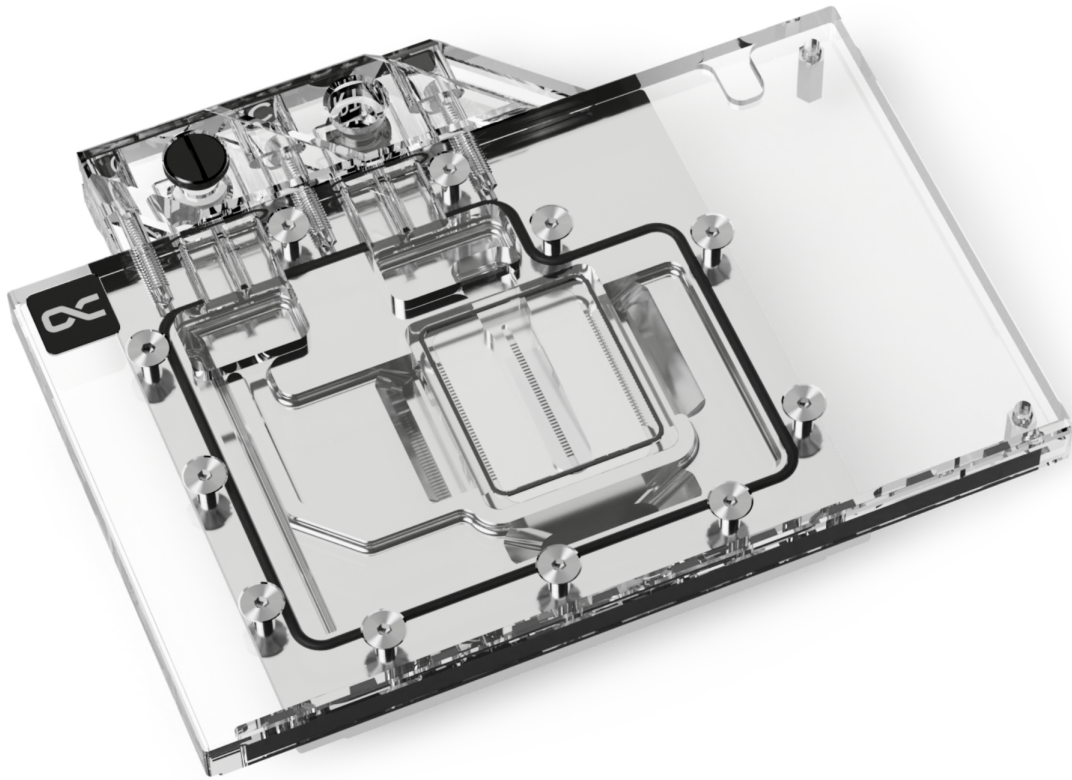

Quick Info

The next generation - the Alphacool Eisblock Aurora water cooler for Geforce RTX 4XXX graphics cards. In order to dissipate the enormous heat of this graphics card generation in the best possible way, numerous optimizations have been made to the water cooler compared to the previous model. The fin structure was adapted and enables a very good water flow while increasing the cooling surface. The modified jet plate with improved inflow engine ensures an optimal distribution of the water on the cooling fins.

- Optimised fin structure enables very good water flow & increase of cooling surface
- Modified jet plate ensures optimal distribution of the water on the cooling fins
- Chrome-plated copper cooler
- Visually calm & simple design with digital aRGB illumination

Compatibility

- Gigabyte GeForce RTX 4070 Ti Eagle 12G, 12GB GDDR6X (GV-N407TEAGLE-12G)
- Gigabyte GeForce RTX 4070 Ti Eagle OC 12G, 12GB GDDR6X (GV-N407TEAGLE OC-12G)
- Gigabyte GeForce RTX 4070 Ti Gaming OC 12G, 12GB GDDR6X (GV-N407TGAMING OC-12GD)
- Gigabyte GIGABYTE GeForce RTX 4070 Ti Aero OC 12G, 12GB GDDR6X, HDMI, 3x DP (GV-N407TAERO OC-12GD)
- Gigabyte GeForce RTX 4070 Ti SUPER Gaming OC 16G, 16GB GDDR6X (GV-N407TSGAMING OC-16GD)

Scope of delivery

1x Alphacool Eisblock Aurora Geforce RTX 4070 TI Eagle OC	4x EVA Washer
1x Backplate	4x M2x5mm Screw
4x 8x8x1mm Pad	1x 45x45x3mm GPU-Pad
1x 25x15x1mm Pad	3x 40x8x3mm Pad
1x 40x15x1mm Pad	1x 85x8x3mm Pad
1x 51x15x1mm Pad	4x M2x11mm Screw
1x 85x8x1mm Pad	1x ARGB Adapter
1x Thermal Grease	2x G1/4 Plug
1x Putty tool	1x Plug tool

Technical data cooler

Dimensions (L x W x H)	176,60 x 134,00 x 34,40mm
Material cooler	chrome-plated copper
Material cooler top	acrylic
Threads	4 x G1/4"
Thickness cooling fins	0,4mm
Distance cooling fins	0,4mm
Illumination	digital aRGB LEDs
Power connector digital aRGB LEDs	3-Pin JST
Power digital aRGB LEDs	5V
Number of digital aRGB LEDs	13
Color	transparent

Technical data backplate

Dimensions (L x W x H)	176,60 x 109,50 x 6mm
Material	aluminium
Color	black

Download links

Manual	13729_Alphacool_Eisblock_Aurora_Geforce_RTX_4070_TI_Eagle_OC_with_Backplate_Manual.pdf
Product pictures	13729_Alphacool_Eisblock_Aurora_Geforce_RTX_4070_TI_Eagle_OC_with_Backplate_pics.zip

Packaging dimensions per unit

L x W x H	355 x 170 x 45 mm
Weight	1500 g

Other data

Certificates	CE, FC, RoHS
EAN	4250197137294
Customs code	84195080900

Article text

The next generation - the Alphacool Eisblock Aurora water cooler for Geforce RTX 40XX graphics cards. In order to dissipate the enormous heat of this graphics card generation in the best possible way, numerous optimizations have been made to the water cooler compared to the previous model. The fin structure was adapted and enables a very good water flow while increasing the cooling surface. The modified jet plate with improved inflow engine ensures an optimal distribution of the water on the cooling fins.

Technical Highlights

The fin structure of this Eisblock cooler generation was developed together with Nvidia board partners. The fin thickness is 0.4 mm, the distance between the cooling fins is 0.4 mm. This ensures a very good water flow while increasing the cooling surface. The jet plate has a revised inlay that spreads the water pressure better over the fins thus optimizing the heat absorption. The adjusted water inflow gives the water a better angle of inflow.

Chrome-plated copper

The cooler is made entirely of chrome-plated copper. A chrome plating is much harder than a nickel plating and therefore less sensitive to acids, scratches and damage. It completely eliminates the risk of chipping nickel plating. Additionally, chrome plating looks much more homogeneous and provides a shine that cannot be achieved by nickel plating. Chrome-plated coolers have previously only been used in the industrial sector in areas where extreme influences act on the coolers.

Design

The Aurora design of the Geforce RTX 40XX Eisblock generation is visually calmer and simpler. Only one O-ring runs around the entire cooler. The design around the cooling fins and jetplate makes for a cleaner look. The illumination of the digitally addressable RGB LEDs is even better distributed throughout the cooler as a result of the chrome plating. The terminal's design is in line with the classic Aurora design.

Thermal paste & thermal pads

The included thermal compound is Alphacool's Subzero. With a thermal conductivity of 16 W/mK, it is one of the highest performing thermal pastes on the market. The electrically non-conductive thermal compound is particularly well suited for high contact pressures, but can still be processed perfectly due to its viscosity of 850,000 TF. Alphacool Soft Pads with 0,5mm thickness are used on the voltage converter and the graphics memory. The thermal conductivity of the pads is 7 W/mK. The pads for the back of the PCB are 3mm thick and have a thermal conductivity of 3 W/mK.

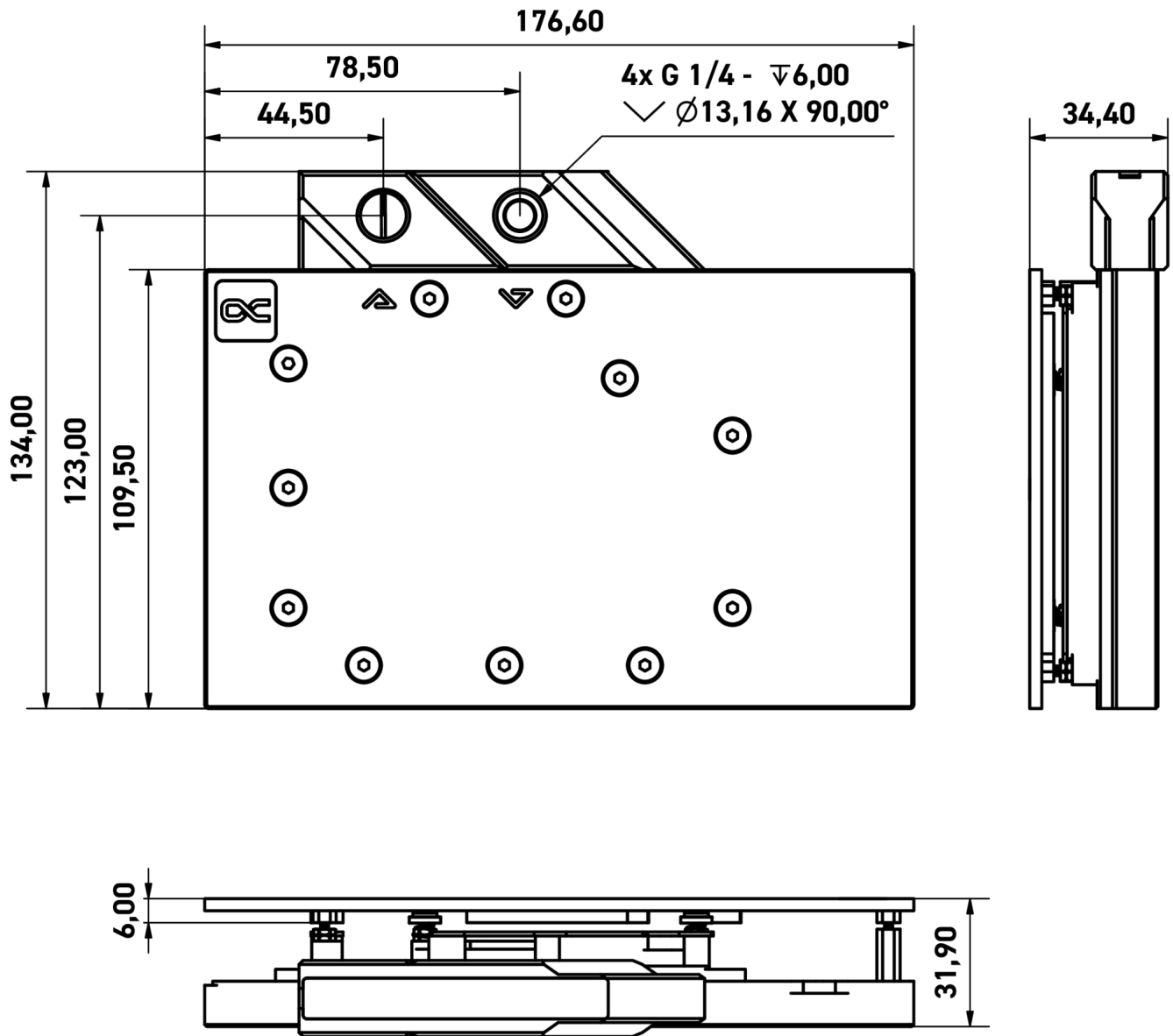

General tolerance: $\pm 0,25\text{mm}$
Dimension in millimeter